

EasyLine Continuous Gas Analyzers

Models EL3020, EL3040

Data Sheet

10/24-4.10 EN May 2006



- Detectors with different measurement principles for numerous process and emission monitoring applications
- Up to five measurement components per gas analyzer
- Suitable for measuring flammable gases
- Automatic calibration including pump and valve control
- Simplified calibration with air or integral calibration cells eliminating the need for test gas cylinders
- Customizable analog outputs, digital inputs and digital outputs
- Modbus interface
- Simple menu-driven operator interface
- Clear-text status messages
- Configuration of rarely required functions with included configuration program
- Self-monitoring function indicates when maintenance is required
- Housing versions for 19-inch rack mounting (Model EL3020) and wall mounting (Model EL3040)
- Integral gas feed (optional in Model EL3020)
- Modular design for ease of service

Overview of the Gas Analyzers	3
Infrared Photometer Uras26	4
Oxygen Analyzer Magnos206	6
Thermal Conductivity Analyzer Caldos27	8
Electrochemical Oxygen Sensor	10
Integral Gas Feed	11
General Data	11
Dimensional Drawings	13
Electrical Connections	15
Gas Connections Model EL3020	18
Gas Connections Model EL3040	20
Certifications	22

Measuring Technology (Analyzers)

The following analyzers are available for selection:

- Uras26 infrared photometer for the measurement of infrared-active gas components e.g. CO, NO, SO₂
- Magnos206 oxygen analyzer for the measurement of O₂ in process gas or in N₂
- Caldos27 thermal conductivity analyzer for the measurement of binary gas mixtures with different thermal conductivity e.g. Ar in O₂, H₂ in Ar, CH₄ in N₂

- Electrochemical oxygen sensor for the measurement of O₂

The electrochemical oxygen sensor can only be used in combination with the Uras26 infrared photometer.

The Magnos206 oxygen analyzer and the Caldos27 thermal conductivity analyzer can also be used in combination with the Uras26 infrared photometer.

Up to five measurement components can be measured with one gas analyzer.

Integral Gas Feed

The integral gas feed (optional in Model EL3020) includes the solenoid valve, pump, coarse filter, capillary tube and flow sensor modules. The flow sensor is also available separately.

Electrical Interfaces

The electrical interfaces for the output of measured values and communication with external systems include

- The integrated Ethernet-10/100BASE-T interface (for service and configuration purposes)

as well as the integrated I/O modules depending on the functional range and order

- Analog output module with 2 analog outputs,
- Digital I/O module with 4 digital inputs and 4 digital outputs and
- Modbus module with RS485 and RS232 interfaces.

Housing Design

The housing for the EL3020 gas analyzer model is designed as a 19-inch housing with 3 height units and degree of protection IP20.

The housing for the EL3040 gas analyzer model is designed as a wall-mount housing with degree of protection IP65.

Measurement Principle

Non-dispersive infrared absorption in the $\lambda = 2.5\text{--}8 \mu\text{m}$ wavelength range

Photometer to measure up to 4 components with 1 or 2 beam paths and 1 or 2 receivers per beam path in one gas path or two separate gas paths.

Sample Components and Measurement Ranges

The analyzer has one physical measurement range per sample component. The smallest measurement ranges are shown in the following table.

Sample Component	Smallest Measurement Range
CO	0–100 ppm
CO ₂	0–100 ppm
NO	0–150 ppm
SO ₂	0–100 ppm
N ₂ O	0–100 ppm
CH ₄	0–100 ppm

Measurement Range Limits

Smallest Measurement Range	Largest Measurement Range
0–100 ppm (NO: 0–150 ppm)	0–500 ppm (NO: 0–750 ppm)
0–200 ppm	0–1000 ppm
0–600 ppm	0–3000 ppm
0–2000 ppm	0–10000 ppm
0–0.6 Vol.-%	0–3 Vol.-%
0–2 Vol.-%	0–10 Vol.-%
0–6 Vol.-%	0–30 Vol.-%
0–20 Vol.-%	0–100 Vol.-%

An individual measurement range within the limits shown in the table can be factory-set on special order.

Measurement ranges are freely adjustable within the limits shown in the table.

Measurement ranges should not be set within ignition limits.

Stability

The following data apply only if all influence factors (e.g. flow rate, temperature, atmospheric pressure) are constant.

Linearity Deviation
 $\leq 1\%$ of span

Repeatability
 $\leq 0.5\%$ of span

Zero Drift
 $\leq 1\%$ of span per week

Sensitivity Drift
 $\leq 1\%$ of measured value per week

Output Fluctuation (2σ)
 $\leq 0.2\%$ of span at electronic T90 time (static/dynamic)
 = 5/0 sec

Detection Limit (4σ)
 $\leq 0.4\%$ of span at electronic T90 time (static/dynamic)
 = 5/0 sec

Influence Effects

Flow Effect

Flow rate in the 20–100 l/h range: Within detection limits

Associated Gas Effect/Cross Sensitivity

The knowledge of the sample gas composition is necessary for the analyzer configuration.

Selectivity measures to reduce associated gas effect (optional): Incorporation of interference filters or filter cells, internal electronic cross-sensitivity correction for one sample component by other sample components measured with the gas analyzer.

Temperature Effect

Ambient temperature in permissible range

- At zero-point: $\leq 2\%$ of span per 10 °C
 - On sensitivity without thermostat:
 $\leq 3\%$ of measured value per 10 °C
 - On sensitivity with thermostat (optional):
 $\leq 2\%$ of measured value per 10 °C
- Thermostat temperature = 55 °C

Air Pressure Effect

- At zero-point: No effect
- On sensitivity with pressure correction by means of integral pressure sensor: $\leq 0.2\%$ of measured value per 1% barometric pressure change

The pressure sensor is located in the sample gas path if hoses are used as the internal gas lines.

If tubing is used for internal gas lines the pressure sensor is routed to the outside via a hose.

Pressure sensor working range: $p_{\text{abs}} = 600\text{--}1250 \text{ hPa}$

Power Supply Effect

Voltage and frequency in the permissible range: No effect

Infrared Photometer Uras26

Dynamic Response

Warm-Up Time

Approx. 30 minutes without thermostat; approx. 2 hours with thermostat

90% Response Time

$T_{90} = 2.5$ sec for measurement cell length = 175 mm, sample gas flow = 60 l/h and electronic T90 time (static/dynamic) = 5/0 sec.

Calibration

Zero-Point Calibration

With inert gas, e.g. N_2 , or with ambient air that is free of the sample component.

End-Point Calibration

With gas-filled calibration cells (optional) or with test gas mixtures. It is recommended to verify the calibration cell set values once a year.

Materials in Contact with the Sample Medium

Analyzer (Sample Cells)

Tubing: Aluminum; Window: CaF_2 or BaF_2 ; Connectors: Stainless steel 1.4305

Gas Lines and Connectors

FPM (Fluorocarbon rubber) hoses, PVDF connectors; Option: Stainless steel tubes 1.4571, stainless steel connectors 1.4305

Gas Inlet Conditions

The analyzer must not be used for measurement of ignitable gas/air or gas/oxygen mixtures.

Temperature

The sample gas dew point should be at least 5 °C below the temperature throughout the sample gas path. Otherwise a sample gas cooler or condensate trap is required.

Inlet Pressure

$p_e = 2-500$ hPa

Lower pressures require a sample gas pump and higher pressures require a pressure reducer.

Outlet Pressure

Atmospheric pressure

Flow Rate

20-100 l/h

Corrosive Gases

Highly corrosive associated gas components, e.g. chlorine (Cl_2) and hydrogen chloride (HCl), as well as gases or aerosols containing chlorine must be cooled or undergo prior absorption.

Flammable Gases

In the version with gas lines and connectors made of stainless steel the analyzer is suitable for measuring flammable gases in general purpose environment. Please observe the special conditions (see operator's manual).

Gas Connections

see page 18 (Model EL3020) and page 20 (Model EL3040)

Oxygen Analyzer Magnos206

Measurement Principle

Paramagnetic behavior of oxygen

Magnetomechanical oxygen analyzer; short 90% response time

Sample Component and Measurement Range

Sample Component

Oxygen (O₂)

Smallest Measurement Range

0–2 Vol.-% O₂

Quantity and Measurement Range Limits

1 measurement range

The measurement range limits are freely adjustable; they are factory-set per order to 0–100 Vol.-% O₂ or 98–100 Vol.-% O₂.

Largest Measurement Range

0–100 Vol.-% O₂

Measurement ranges should not be set within ignition limits.

Measurement Ranges with Suppressed Zero-Point

Smallest span 2 Vol.-% O₂. The suppressed measurement range is factory-set to 98–100 Vol.-% O₂. A pressure sensor is installed when the analyzer has been ordered with suppressed measurement range.

Stability

The following data apply only if all influence factors (e.g. flow rate, temperature, atmospheric pressure) are constant. They are based on a span of 2 Vol.-% O₂.

Linearity Deviation

≤ 0.5 % of span

Repeatability

≤ 1% of span (time base for gas exchange 3 minutes)

Zero Drift

≤ 0.1 Vol.-% O₂ per week; following prolonged transport and storage time the drift can be higher during the first weeks of operation.

Sensitivity Drift

≤ 0.1 Vol.-% O₂ per week or ≤ 1% of measured value per week (not cumulative), whichever is smaller.

Output Fluctuation (2 σ)

≤ 0.5 % of smallest measurement range span at electronic
T90 time (static/dynamic) = 3/0 sec

Detection Limit (4 σ)

≤ 1% of smallest measurement range span at electronic
T90 time (static/dynamic) = 3/0 sec

Influence Effects

Flow Effect

≤ 0.1 Vol.-% O₂ in the 30–90 l/h range

Associated Gas Effect

The effect of associated gases as a shift of the zero-point – expressed in Vol.-% O₂ – can be estimated using the approximate values in the following table:

Associated Gas Concentration 100 Vol.-%		Zero-Point Shift in Vol.-% O ₂
Hydrogen	H ₂	+0.28
Hydrogen Sulfide	H ₂ S	-0.45
Argon	Ar	-0.26
Helium	He	+0.30
Neon	Ne	+0.13
Nitrogen	N ₂	0
Nitrogen Oxide	NO	+43
Nitrogen Dioxide	NO ₂	+28
Nitrous Oxide	N ₂ O	-0.20
Carbon Monoxide	CO	-0.01
Carbon Dioxide	CO ₂	-0.32
Carbon Oxysulfide	COS	-0.90
Ethane	C ₂ H ₆	-0.46
Ethylene	C ₂ H ₄	-0.29
Methane	CH ₄	-0.24
Propane	C ₃ H ₈	-0.98
Propylene	C ₃ H ₆	-0.55
Trichloroethane	C ₂ HCl ₃	-2.17
Vinyl Chloride	CH ₂ CHCl	-0.75

For further associated gases refer to EN 61207-3

Temperature Effect

Ambient temperature in the permissible range
– At zero-point: ≤ 1% of span per 10 °C, ≤ 2% of span per 10 °C in combination with Uras26
– On sensitivity: ≤ 0.2% of measured value per 10 °C
Thermostat temperature = 64 °C

Air Pressure Effect

– At zero-point: No effect
– On sensitivity with no pressure correction:
≤ 1% of measured value per 1% air pressure change
– On sensitivity with pressure correction using integrated pressure sensor (optional):
≤ 0.01% of measured value per 1% pressure change or
≤ 0.002 Vol.-% O₂ per 1% pressure change, whichever is greater
Pressure sensor working range: p_{abs} = 600–1250 hPa

Power Supply Effect

Voltage and frequency in the permissible range: ≤ 0.2% of span

Position Effect

Zero-point shift ≤ 0.05 Vol.-% O₂ per 1° deviation from horizontal orientation. Position has no effect on the hard-mounted unit.

Oxygen Analyzer Magnos206

Dynamic Response

Warm-Up Time
< 1 hour

90% Response Time
 $T_{90} \leq 4$ sec at a sample gas flow of 90 l/h and electronic T90 time (static/dynamic) = 3/0 sec, gas change from N₂ to air

Calibration

Zero-Point Calibration
With oxygen-free process gas or substitute gas

End-Point Calibration
With process gas with a known oxygen concentration or a substitute gas such as dried air

Single-Point Calibration
For measurement ranges from 0 to 5 Vol.-% O₂ to 0 to 25 Vol.-% O₂
Zero-point calibration with any oxygen concentration, e.g. with nitrogen (N₂) or ambient air, processed through a cooler or H₂O absorber; sensitivity deviation ≤ 0.05 Vol.-% O₂ per year.
Pressure correction by means of pressure sensor is recommended for single-point calibration with air.
Depending on the measurement task involved, the zero- and end-points should be verified periodically.

Calibration of Measurement Ranges with Suppressed Zero-Point
Highly suppressed measurement ranges (≥ 95 –100 Vol.-% O₂) should only be calibrated with test gases with concentrations in the selected measurement range.

Materials in Contact with the Sample Medium

Analyzer
Sample chamber (direct connection): Stainless steel 1.4305, glass, platinum, rhodium, epoxy resin;
Seals: FPM (Fluorocarbon rubber), PEEK

Gas Inlet Conditions

The analyzer must not be used for measurement of ignitable gas/air or gas/oxygen mixtures.

Temperature
+5 to +50 °C
The sample gas dew point should be at least 5 °C below the temperature throughout the sample gas path. Otherwise a sample gas cooler or condensate trap is required. Water vapor content variations cause volume errors.

Inlet Pressure
 $p_e = 2$ –100 hPa
Lower pressures require a sample gas pump and higher pressures require a pressure reducer.

Outlet Pressure
Atmospheric pressure

Flow Rate
30–90 l/h
Abrupt changes in gas flow rates should be avoided when using highly suppressed measurement ranges.

Corrosive Gases
Consultation with ABB Analytical is required if the sample gas contains Cl₂, HCl, HF or other corrosive components.
The AO2000-Magnos106 analyzer should be used if the sample gas contains NH₃.

Flammable Gases
The analyzer is suitable for measuring flammable gases in general purpose environment. Please observe the special conditions (see operator's manual).

Gas Connections
see page 19 (Model EL3020) and page 21 (Model EL3040)

Thermal Conductivity Analyzer Caldos27

Measurement Principle

Difference in thermal conductivity of various gases

Micromechanical silicon sensor with especially short T_{90} time

Largest Measurement Range

0–100 Vol.-% or 0 Vol.-% to saturation, depending on measurement task

Measurement ranges should not be set within ignition limits.

Sample Components and Measurement Ranges

Sample Component and Associated Gas	Smallest Meas. Range	Smallest Meas. Range With Suppr. Zero-Point
Air in Ar	0– 6 Vol.-%	94–100 Vol.-%
Ar in air	0– 6 Vol.-%	94–100 Vol.-%
Air in CO ₂	0–10 Vol.-%	90–100 Vol.-%
CO ₂ in air	0–10 Vol.-%	90–100 Vol.-%
Air in H ₂	0– 3 Vol.-%	–
H ₂ in air	0– 1 Vol.-%	–
Air in He	0– 3 Vol.-%	98–100 Vol.-%
He in air	0– 2 Vol.-%	97–100 Vol.-%
Ar in CO ₂	–	50–100 Vol.-%
CO ₂ in Ar	0–50 Vol.-%	–
Ar in H ₂	0– 3 Vol.-%	99–100 Vol.-%
H ₂ in Ar	0– 1 Vol.-%	97–100 Vol.-%
Ar in He	0– 3 Vol.-%	99–100 Vol.-%
He in Ar	0– 1 Vol.-%	97–100 Vol.-%
Ar in N ₂	0– 6 Vol.-%	94–100 Vol.-%
N ₂ in Ar	0– 6 Vol.-%	94–100 Vol.-%
Ar in O ₂	0–10 Vol.-%	90–100 Vol.-%
O ₂ in Ar	0–10 Vol.-%	90–100 Vol.-%
CH ₄ in H ₂	0– 3 Vol.-%	99–100 Vol.-%
H ₂ in CH ₄	0– 1 Vol.-%	97–100 Vol.-%
CH ₄ in N ₂	0– 6 Vol.-%	94–100 Vol.-%
N ₂ in CH ₄	0– 6 Vol.-%	94–100 Vol.-%
CO in H ₂	0– 3 Vol.-%	99–100 Vol.-%
H ₂ in CO	0– 1 Vol.-%	97–100 Vol.-%
CO ₂ in H ₂	0– 3 Vol.-%	99–100 Vol.-%
H ₂ in CO ₂	0– 1 Vol.-%	97–100 Vol.-%
CO ₂ in N ₂	0–10 Vol.-%	90–100 Vol.-%
N ₂ in CO ₂	0–10 Vol.-%	90–100 Vol.-%
H ₂ in N ₂	0– 1 Vol.-%	97–100 Vol.-%
N ₂ in H ₂	0– 3 Vol.-%	99–100 Vol.-%
H ₂ in NH ₃	0–10 Vol.-%	90–100 Vol.-%
NH ₃ in H ₂	0–10 Vol.-%	90–100 Vol.-%
He in N ₂	0– 2 Vol.-%	97–100 Vol.-%
N ₂ in He	0– 3 Vol.-%	98–100 Vol.-%

Measurement Ranges for Monitoring Hydrogen-Cooled Turbo Generators

Sample Component and Associated Gas	Measurement Range
CO ₂ in air or Ar in air	0–100 Vol.-%
H ₂ in CO ₂ or H ₂ in Ar	100–0 Vol.-%
H ₂ in air	100–80 Vol.-%

Other sample components on request.

Quantity and Measurement Range Limits

1 measurement range

Ranges are freely adjustable within the range limits given in the table.

Stability

The following data apply only if all influence factors (e.g. flow rate, temperature, atmospheric pressure) are constant. They relate to smallest measurement ranges given in the table. The deviations may be larger for smaller measurement ranges.

Linearity Deviation

≤ 2 % of span

Repeatability

≤ 1 % of span

Zero Drift

≤ 2 % of smallest possible measurement range per week

Sensitivity Drift

≤ 0.5 % of smallest possible measurement range per week

Output Fluctuation (2 σ)

≤ 0.5 % of smallest measurement range span at electronic T90 time = 0 sec

Detection Limit (4 σ)

≤ 1 % of smallest measurement range span at electronic T90 time = 0 sec

Influence Effects

The following data relate to smallest measurement ranges given in the table. The influence effects will be larger at operating altitudes > 2000 meters.

Flow Effect

≤ 0.5 % of span at a flow change of ±10 l/h. At an identical flow rate for test and sample gases the flow rate effect is automatically compensated.

Associated Gas Effect

The knowledge of the sample gas composition is necessary for the analyzer configuration. If the sample gas contains components in addition to the sample component and associated gas (binary gas mixture), this will result in erroneous measurements.

Temperature Effect

Ambient temperature in the permissible range at each point in the measurement range: ≤ 1 % of span per 10 °C, based on temperature at the time of calibration
Thermostat temperature = 60 °C

Air Pressure Effect

≤ 0.25 % of span per 10 hPa for the smallest possible ranges given; for larger spans the effect is correspondingly lower.
Pressure sensor working range: $p_{\text{abs}} = 600\text{--}1250$ hPa

Power Supply Effect

Voltage and frequency in the permissible range: ≤ 0.2 % of span

Position Effect

< 1 % of span up to 30° deviation from horizontal orientation

Thermal Conductivity Analyzer Caldos27

Dynamic Response

Warm-Up Time

Approx. 30 minutes

90% Response Time

$T_{90} \leq 2$ sec at sample gas flow of 60 l/h and electronic

T90 time (static/dynamic) = 0/0 sec

Calibration

Zero-Point Calibration

With test gas, measurement component-free process gas or substitute gas

End-Point Calibration

With test gas, process gas having a known sample gas concentration or substitute gas

Single-Point Calibration

A single-point calibration can be performed with standard gas, since the zero- and end-points will not drift independently due to the sensor principle employed. This technique leaves out safety-related measurements. Depending on the measurement task involved, the zero- and end-points should be verified periodically (Recommendation: once a year).

Materials in Contact with the Sample Medium

Analyzer

Sample chamber (direct connection): Stainless steel 1.4305;

Sensor: Gold, silicon oxi-nitride; Seal: FFKM75 (Perfluoro rubber)

Gas Inlet Conditions

The analyzer must not be used for measurement of ignitable gas/air or gas/oxygen mixtures.

Temperature

+5 to +50 °C

The sample gas dew point should be at least 5 °C below the temperature throughout the sample gas path. Otherwise a sample gas cooler or condensate trap is required. Water vapor content variations cause volume errors.

Inlet Pressure

$p_e = 2-100$ hPa

Lower pressures require a sample gas pump and higher pressures require a pressure reducer.

Outlet Pressure

Atmospheric pressure

Flow Rate

Normally 10–90 l/h, minimum 1 l/h

Pressure Drop

< 2 hPa at 60 l/h N₂

Corrosive Gases

Consultation with ABB Analytical is required if the sample gas contains Cl₂, HCl, HF, SO₂, NH₃, H₂S or other corrosive components.

Flammable Gases

The analyzer is suitable for measuring flammable gases in general purpose environment. Please observe the special conditions (see operator's manual).

Gas Connections

see page 19 (Model EL3020) and page 21 (Model EL3040)

Electrochemical Oxygen Sensor

Measurement Principle

Electrochemical oxygen sensor

Sample Component and Measurement Range

Sample Component
Oxygen (O₂)

Smallest Measurement Range
0–5 Vol.-% O₂

Measurement Range
Adjustable from 0–5 Vol.-% O₂ to 0–25 Vol.-% O₂

Stability

Linearity Deviation
Linear in the range > 1 Vol.-% O₂

Repeatability
≤ 0.5 % of span

Zero Drift
Stable over long-term due to absolute zero point

Sensitivity Drift
≤ 1 % of the measurement range per week

Output Fluctuation (2 σ)
≤ 0.2 % of the measurement range at electronic T90 time
(static/dynamic) = 5/0 sec

Detection Limit (4 σ)
≤ 0.4 % of the measurement range at electronic T90 time
(static/dynamic) = 5/0 sec

Influence Effects

Flow Effect
Flow rate in the 20–100 l/h range:
≤ 2 % of the measurement range

Temperature Effect
Ambient temperature in the +5 to +40 °C range:
≤ 0.2 Vol.-% O₂ per 10 °C

Air Pressure Effect

- At zero-point: No effect
- On sensitivity with no pressure correction:
≤ 1 % of measured value per 1 % air pressure change
- On sensitivity with pressure correction:
≤ 0.2 % of sample value per 1 % air pressure change

Pressure correction is only possible if the oxygen sensor is connected to the Uras26 infrared photometer with an integral pressure sensor.

Power Supply Effect
Voltage and frequency in the permissible range: ≤ 0.2 % of span

Dynamic Response

90% Response Time
T₉₀ ≤ 30 sec at sample gas flow of 60 l/h and electronic
T90 time (static/dynamic) = 5/0 sec

Calibration

Zero-Point Calibration
The oxygen sensor zero is not calibrated since it is fundamentally stable.

End-Point Calibration
With ambient air at 20.96 Vol.-% O₂

Materials in Contact with the Sample Medium

Sensor
Polystyrol-ABS, PTFE, FPM (Fluorocarbon rubber)

Housing Body
PVC, FPM (Fluorocarbon rubber) seals

Gas Ports
Stainless steel 1.4571

Gas Inlet Conditions

The oxygen sensor must not be used for measurement of flammable gases and ignitable gas/air or gas/oxygen mixtures.

Temperature
The sample gas dew point should be at least 5 °C below the temperature throughout the sample gas path. Otherwise a sample gas cooler or condensate trap is required.

Moisture Content
H₂O dew point ≥ 2 °C
The oxygen sensor should not be used with dry sample gas.

Inlet Pressure
p_e = 2–500 hPa

Outlet Pressure
Atmospheric pressure

Flow Rate
20–100 l/h

Associated Gas
The oxygen sensor should not be used if the associated gas contains the following components: H₂S, chlorine or fluorine compounds, heavy metals, aerosols, mercaptane, base components.

Note

The oxygen sensor can only be used in combination with the Uras26 infrared photometer. It cannot be used when the internal gas paths in the Uras26 are made up of stainless steel pipes.

Integral Gas Feed

The integral gas feed (optional in Model EL3020) includes the solenoid valve, pump, coarse filter, capillary tube and flow sensor modules. The flow sensor is also available separately. The integral gas feed cannot be installed in the version with internal gas lines made of stainless steel.

Test Gas Supply

Version

3/2-way solenoid valve

Power Consumption

Approx. 3 W

Materials in Contact with the Sample Medium

PVDF, FPM

Gas Feed

Version

Magnetic piston pump

Feed Rate

Max. of 60 l/h, depending on the analyzer type and inlet/outlet pressure

Flow Rate

Adjustable

Power Consumption

Approx. 10 W

Materials in Contact with the Sample Medium

PVDF, EPDM, stainless steel 1.4571

Flow Monitor

Version

Miniature flow sensor

Materials in Contact with the Sample Medium

Al₂O₃, silicon, gold, GFK

Gas Inlet Conditions

The integral gas feed modules must not be used for measurement of flammable gases and ignitable gas/air or gas/oxygen mixtures.

Temperature

+5 to +45 °C

The sample gas dew point should be at least 5 °C below the temperature throughout the sample gas path. Otherwise a sample gas cooler or condensate trap is required.

Flow Rate

30–60 l/h

Corrosive Gases

Corrosive associated gas components and aerosols must be cooled or undergo prior absorption.

General Data

Housing

	Model EL3020	Model EL3040
Version	19-inch housing	Wall-mount housing
Protection Type	IP20	IP65
Materials		
Housing	Galvanized sheet steel Outer surfaces varnished	Stainless steel
Analyzer Rear Panel	Aluminum, PVC-C	
Keypad Sheet	Polyester	
Colors	Light gray (RAL 7035), basalt gray (RAL 7012)	
Weight	approx. 7–15 kg	approx. 13–21 kg
Dimensions	see page 13	see page 14

Housing Purge

Possible only with Model 3040 (wall-mount housing);

Purge gas flow during operation max. 20 l/h,

Purge gas pressure $p_e = 2\text{--}4$ hPa

Display and Operation

Display

Backlit graphics display with 240 x 160-pixel resolution

Measured value display

- Numerical value with physical unit, also with bar graph indication in single display
- Resolution better than 0.2 % of the measurement span
- Simultaneous display of up to 5 measured values
- Flow: bar graph indication

Status display

Symbols in the display; the active status messages can be accessed directly from the measured value display

Operation

5 keys (cursor cross and OK); menu-assisted operation

Limit Value Monitoring

Limit values can be set using the configuration program.

The limit value signals (alarms) are output via the digital ports.

Pressure Sensor

Use

Standard for Uras26 and Caldos27, option for Magnos206

Materials in Contact with the Sample Medium

Silicon gel, plastics, FPM (Fluorocarbon rubber)

Fine Filtration

Version

Disposable filter with Borosilicate glass microfiber filter element

Retention Rate

99.99 % for particles > 0.1 µm

Materials in Contact with the Sample Medium

Polyamide, borosilicate glass with PVDF binder

General Data

Electromagnetic Compatibility

Noise Immunity

Tested to EN 61326: 1997 + A1: 1998 + A2: 2001 + A3: 2003.
Inspection severity: Industrial area, fulfills at least the rating "continuously monitored operation" to Table 2 of EN 61326.

Emitted Interference

Tested to EN 61326: 1997 + A1: 1998 + A2: 2001 + A3: 2003, EN 61000-3-2: 2000 and EN 61000-3-3: 1995 + A1: 2001.
Limit value class B for interference field strength and interference voltage is met.

Electrical Safety

Tested per EN 61010-1: 2001

Protection Class

I

Overload Category/Pollution Level

Power supply: III/2
Signal inputs and outputs: III/2

Safe Isolation

The power supply is galvanically isolated from other circuits by means of reinforced or double insulation. Operational low voltage (PELV) on low-voltage side

Mechanical Stress

Operation

Vibration test to EN 60068-2-6: 1996
Vibrations up to 0.5g/ 150 Hz have no influence on the measured value. In Uras26, slight transient effects on the measured value can occur in the region of the modulation frequency.

Transport

Vibration test to EN 60068-2-6: 1996,
shock test to EN 60068-2-27: 1995
In its original packaging, the gas analyzer will withstand normal shipping conditions.

Ambient Conditions

Ambient Temperature

Operation: +5 to +45 °C
Uras26 in combination
with another analyzer: +5 to +40 °C
Storage and transport: -25 to +65 °C

Relative Humidity

< 75 %, slight condensation allowed

Air Circulation

For sufficient air circulation, multiple housings in a 19-inch rack must be installed with a separation of at least one height unit between housings.

Power Supply

Input Voltage

100–240 V AC (– 15 %, + 10 %) 50–60 Hz (± 3 Hz)

Power Consumption

Max. 187 W

Connection

3-pin plug per EN 60320-1/C14; connection cable supplied

Explosion-protected Version with Protection Type II 3G for Installation in Hazardous Location for Measurement of Non-flammable Gases and Vapors

The gas analyzer Model EL3040 is tested for explosion protection. It is suitable for installation in hazardous locations when the technical data and the special conditions (see operator's manual) are observed.

The gas analyzer may be used for measurement of non-flammable gases and vapors. It is marked according to the Directive 94/9/EC with

 II 3G EEx nAC II T4 X

In undisturbed operation there cannot be any sparking, arcing or impermissible temperatures inside the device.

Explosion protection through: Non-sparking instruments and devices with low power consumption; sealed or encapsulated devices

Judgment according to EN 60079-15: 2003: Electrical apparatus for explosive gas atmospheres – Part 15: Type of protection "n", Sections 1 to 10, 12, 14, 15, 20

Marking according to EN 60079-15: 2003, Section 28

Housing Degree of Protection IP 65

Version for Measurement of Flammable Gases

In the version with gas lines and connectors made of stainless steel the gas analyzer (Models EL3020 and EL3040) is suitable for measuring flammable gases in general purpose environment. Please observe the special conditions (see operator's manual).

Note Regarding the Performance Characteristics of the Analyzers

The performance characteristics of the analyzers have been determined according to the international standard IEC 1207-1: 1994 "Expression of performance of gas analyzers". They are based on N₂ as the associated gas. Compliance with these characteristics when measuring other gas mixtures can only be assured if their composition is known.

Dimensional Drawings

19-Inch Rack Housing (dimensions in mm)

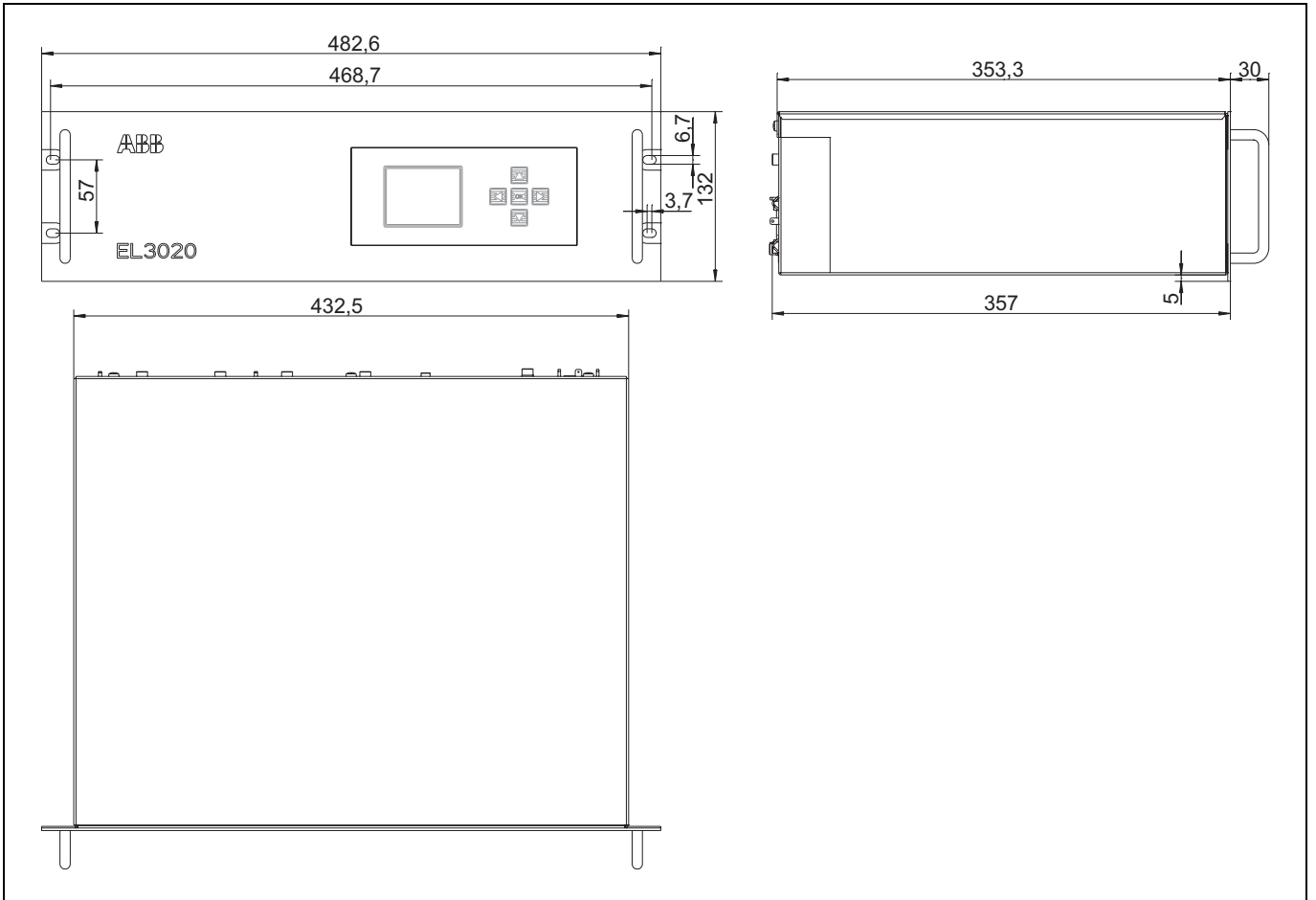

Dimensional Drawings

Wall-mount Housing (Dimensions in mm)

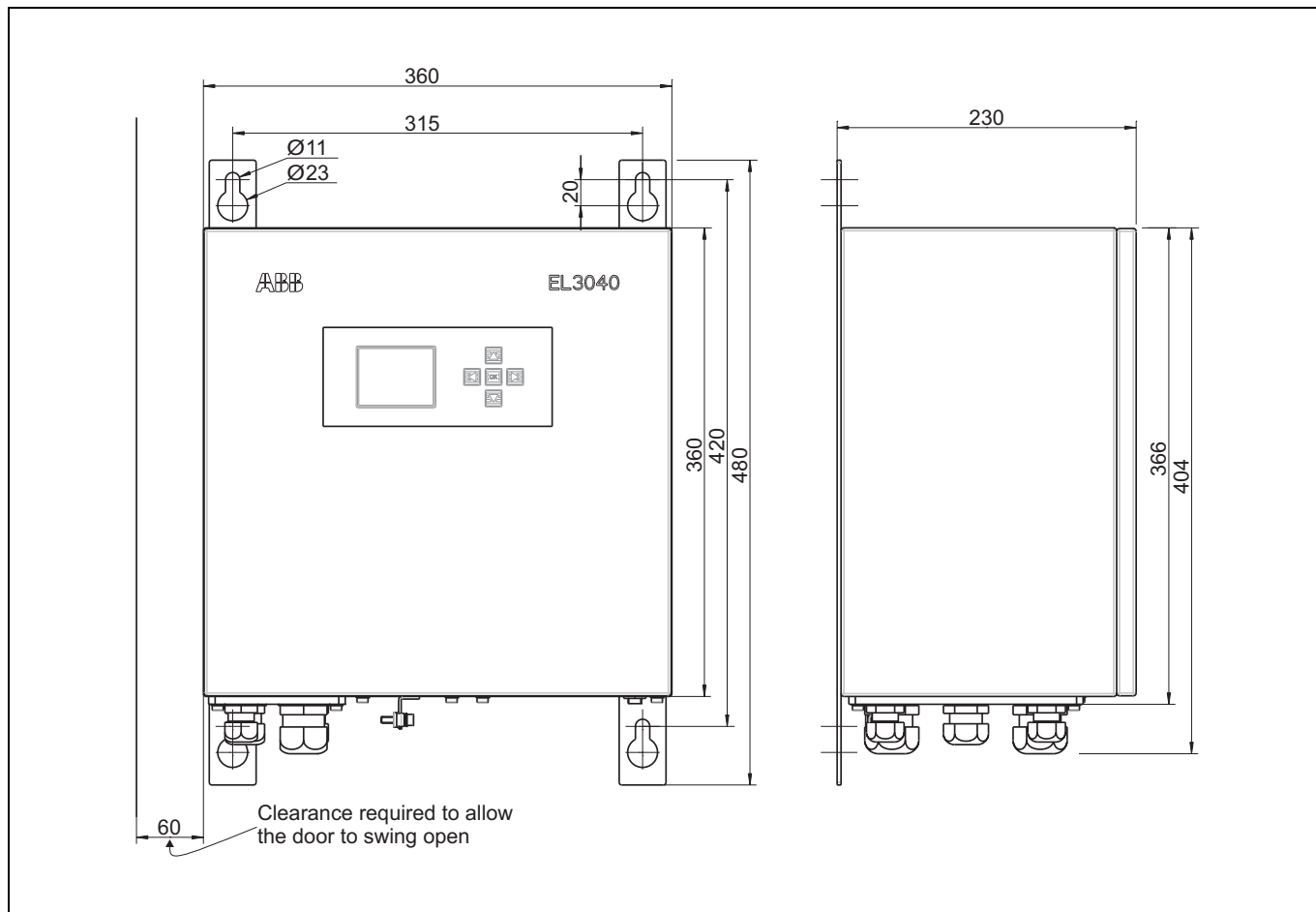

Electrical Connections

Power Supply and Signal Lines Model EL3020 (View from behind)

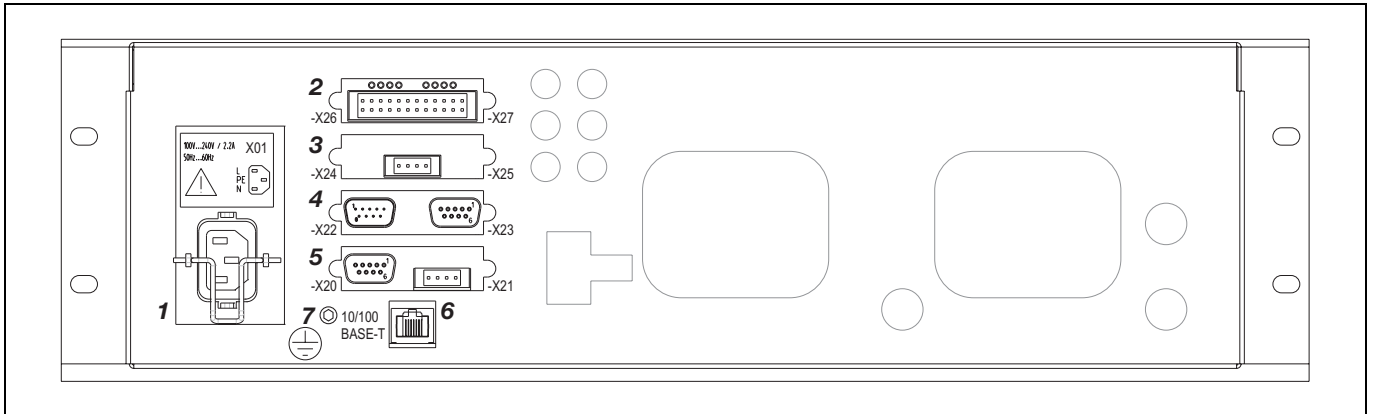

Power Supply and Signal Lines Model EL3040 (View from below)

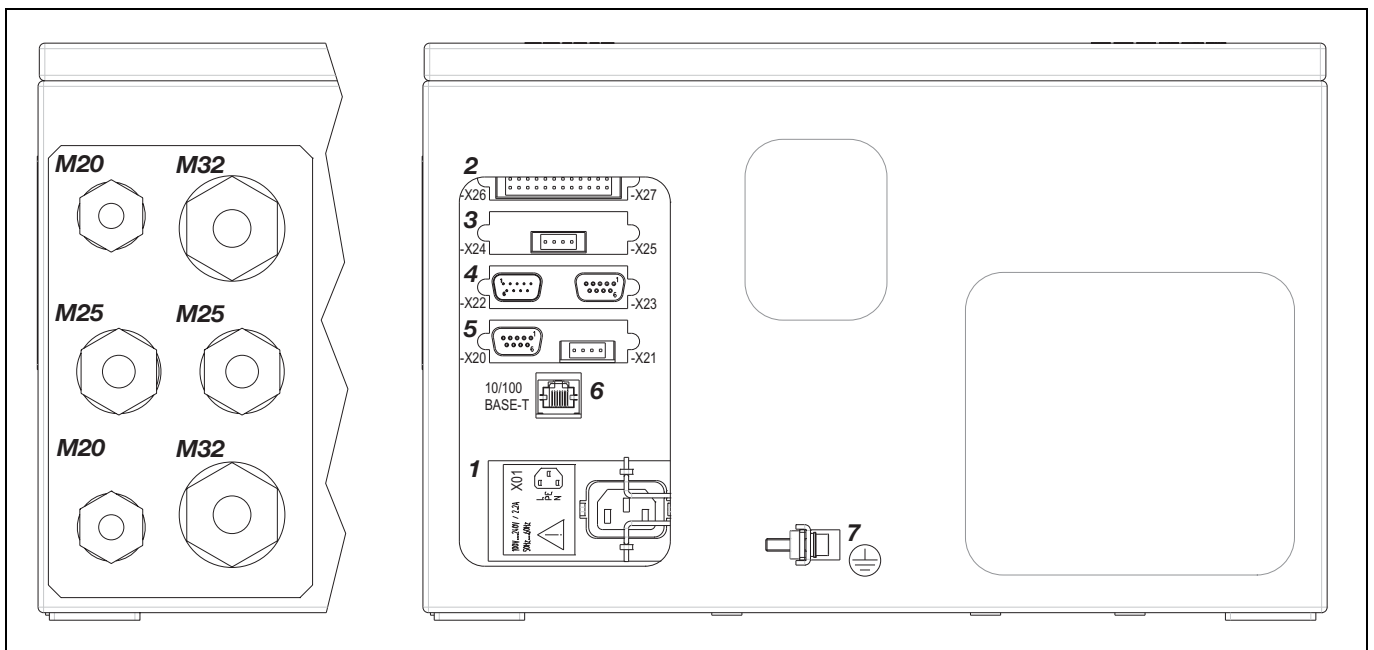

- 1** Power Supply Connection (3-pin plug per EN 60320-1/C14; connection cable supplied)
- I/O Modules (4 slots, assembly example):
- 2** Digital I/O Module (max. 2 modules)
- 3** Analog Output Module (max. 3 modules)
- 4** Modbus Module (RS232 and RS485 interface)
- 5** Profibus Module (in preparation)
- 6** Ethernet-10/100BASE-T Interface for Service and Configuration (8-pin RJ45 plug)
- 7** Potential Compensation Connection (clamping range max. 4 mm²)

Screwed Cable Glands for Cable Diameter:

M20 Power Supply	5–13 mm
M20 Modbus/Profibus	5–13 mm
M25 Network	8–17 mm
M25 3x Analog Outputs	8–17 mm
M32 Digital Inputs/Outputs	12–21 mm
M32 Digital Inputs/Outputs	12–21 mm

Notes Regarding Conductor Section for I/O Module Connection

- The maximum capacity of terminals for stranded or solid conductors is 1 mm² (17 AWG).
- The stranded conductor may be tinned on the tip or twisted for simplified connection.
- When using wire end ferrules the total section should not exceed 1 mm², i.e. the maximum stranded conductor section is 0.5 mm². The Weidmüller PZ 6/5 crimping tool must be used for crimping the ferrules.

Electrical Connections

Analog Output Module

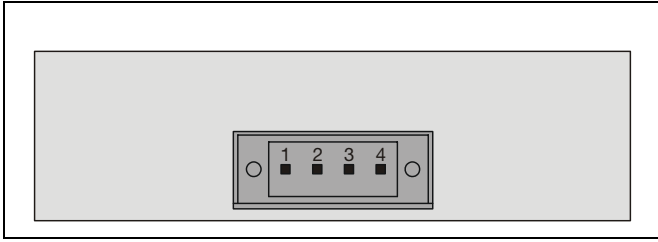

Analog Outputs (AO1, AO2)

0/4–20 mA (configurable, factory-set to 4–20 mA), common negative pole, galvanically isolated from ground, freely connectable to ground, max. gain relative to protective ground potential 50 V, max. working resistance 750 Ω . Resolution 16 bit. The output signal cannot be lower than 0 mA.

Electrical Connections

- 1 AO1+
- 2 AO1–
- 3 AO2+
- 4 AO2–

Design: 4-pin terminal strip for braided or solid conductors with a maximum section of 1 mm² (17 AWG). Observe the notes regarding conductor section (see above)!

Modbus Module

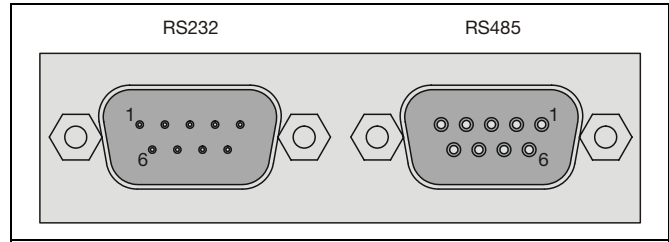

Electrical Connections

RS232 Interface:

- 2 RxD
- 3 TxD
- 5 GND

Design: 9-pin Sub-D male connector

RS485 Interface:

- 2 RTxD–
- 3 RTxD+
- 5 GND

Design: 9-pin Sub-D female connector

Electrical Connections

Digital I/O Module

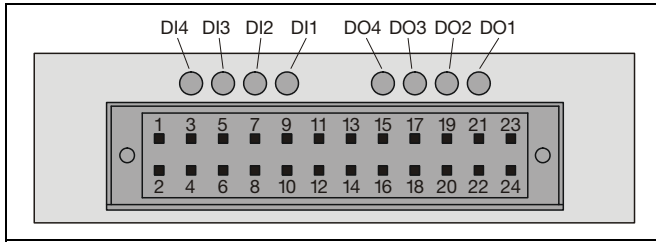

Digital Inputs (DI1 to DI4)

Optocouplers with internal 24 VDC power supply. Control with floating contacts, with external voltage 12–24 VDC or with open collector drivers PNP or NPN.

Digital Outputs (DO1 to DO4)

Floating double-throw contacts, max. contact load rating 30 VDC/1 A

Relays must at all times be operated within the specified data range. Inductive or capacitive loads are to be connected with suitable protective measures (self-induction recuperation diodes for inductive loads and series resistors for capacitive loads).

Digital input and output signals	Standard assignment ¹⁾ Digital I/O Module	
	1	2
Error		
Maintenance request		
Maintenance mode		
Overall status	DO1	
Start automatic calibration	DI1	
Stop automatic calibration		
Disable automatic calibration	DI2	
Sample gas valve	DO4	
Zero gas valve		
Span gas valve		
Pump on/off ²⁾		
Limit 1	DO2	
Limit 2	DO3	
Limit 3		DO1
Limit 4		DO2
Limit 5		DO3
Limit 6		DO4
Limit 7		
Limit 8		
Limit 9		
Limit 10		
Bus DI 1–8		
External failure ³⁾	DI3	
External maintenance request ³⁾	DI4	

1) factory-set, can be changed by on-site configuration

2) when a pump (integral gas feed) is installed

3) Multiple external status signals can be configured depending on the number of free digital inputs.

Connection Diagram

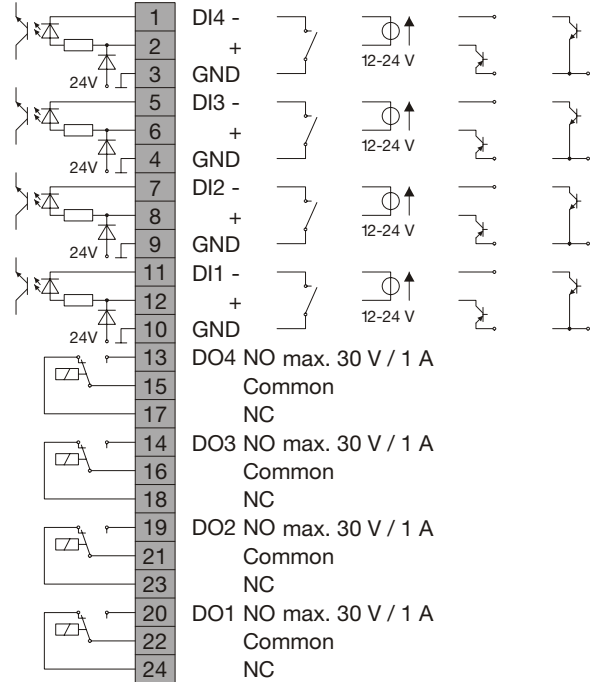

Relays are shown in the unpowered state. The unpowered state is the failure mode.

Electrical Connections

see connection diagram

Design: 2x12-pin terminal strip for braided or solid conductors with a maximum section of 1 mm² (17 AWG). Observe the notes regarding conductor section (see page 15)!

Gas Connections Model EL3020

Analyzer Uras26

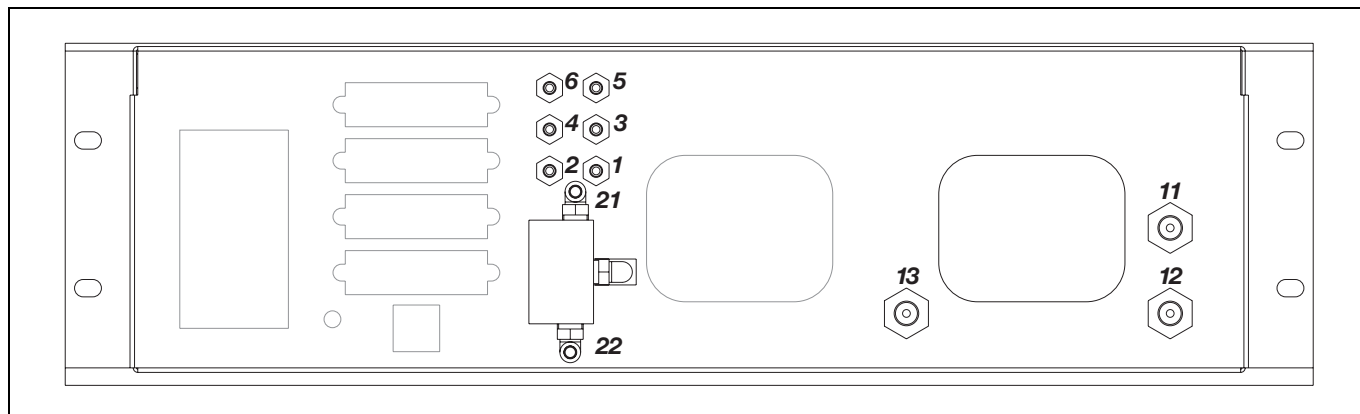

Version with Gas Connections for Hoses (internal gas paths made up of hoses)

- 1** Sample Gas Inlet Gas Path 1 without "Integral Gas Feed" option
- 2** Sample Gas Outlet Gas Path 1 connected to sample gas inlet of Caldos27 or Magnos206 if applicable
- 3** Sample Gas Outlet for "Integral Gas Feed" option, factory-connected to Sample Gas Inlet gas Path 1
- 4** Sample Gas Inlet for "Integral Gas Feed" option with flow sensor only (without solenoid valve)
- 5** Sample Gas Inlet Gas Path 2 } for separate gas paths (for NOx measurement with
- 6** Sample Gas Outlet Gas Path 2 } converter connected upstream)
- 21** Sample Gas Inlet at solenoid valve } for "Integral Gas Feed" option with
- 22** Test Gas Inlet at solenoid valve } solenoid valve, pump, filter, capillary and flow sensor

Design: Hose nozzles (PVDF) for hoses with 4 mm inner diameter

Note: Pressure sensor (standard) and O₂ sensor (option) are connected internally as follows:
downstream the sample cell 1 outlet for one sample cell or for separate gas paths,
downstream the sample cell 2 outlet for two sample cells in series.

Version with Gas Connections for Pipes (internal gas paths made up of stainless steel pipes)

- 6** Pressure Sensor

Design: Hose nozzles (PVDF) for hoses with 4 mm inner diameter

- 11** Sample Gas Inlet
- 12** Sample Gas Outlet for one sample cell } connected to sample gas inlet of
- 13** Sample Gas Outlet for two sample cells in series } Caldos27 or Magnos206 if applicable

Design: 1/8 NPT female thread for threaded connections (not supplied)

Note: O₂ sensor, "Integral Gas Feed" option and version with two separate gas paths cannot be provided.

Gas Connections Model EL3020

Analyzer Magnos206

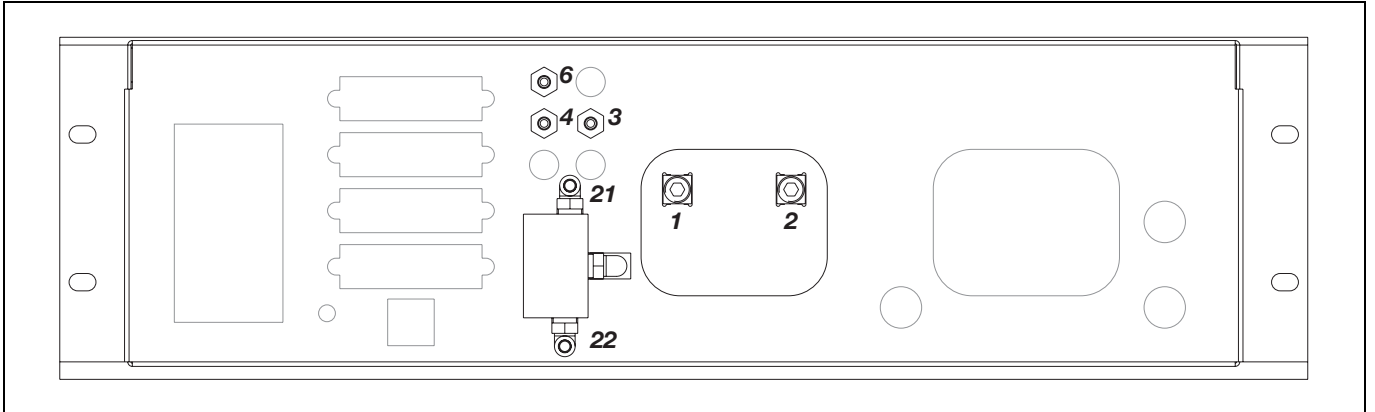

Analyzer Caldos27

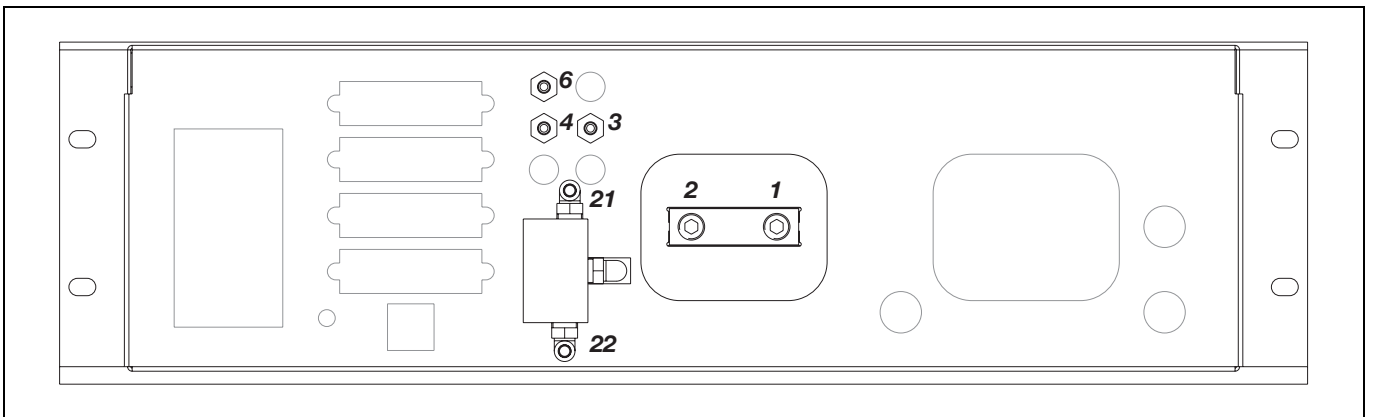

Gas Connections

- 1** Sample Gas Inlet
- 2** Sample Gas Outlet

Design: 1/8 NPT female thread; connection of
flexible tubes: 2 straight screwed fittings (PP) with nozzles for hoses with 4 mm inner diameter (supplied)
pipelines: Threaded connections (not supplied)

- 3** Sample Gas Outlet for "Integral Gas Feed" option, factory-connected to **1** Sample Gas Inlet
- 4** Sample Gas Inlet for "Integral Gas Feed" option with flow sensor only (without solenoid valve)
- 6** Pressure Sensor Option for Magnos206, standard for Caldos27
- 21** Sample Gas Inlet at solenoid valve } for "Integral Gas Feed" option with
- 22** Test Gas Inlet at solenoid valve } solenoid valve, pump, filter, capillary and flow sensor

Design: Hose nozzles (PVDF) for hoses with 4 mm inner diameter

Gas Connections Model EL3040

Analyzer Uras26

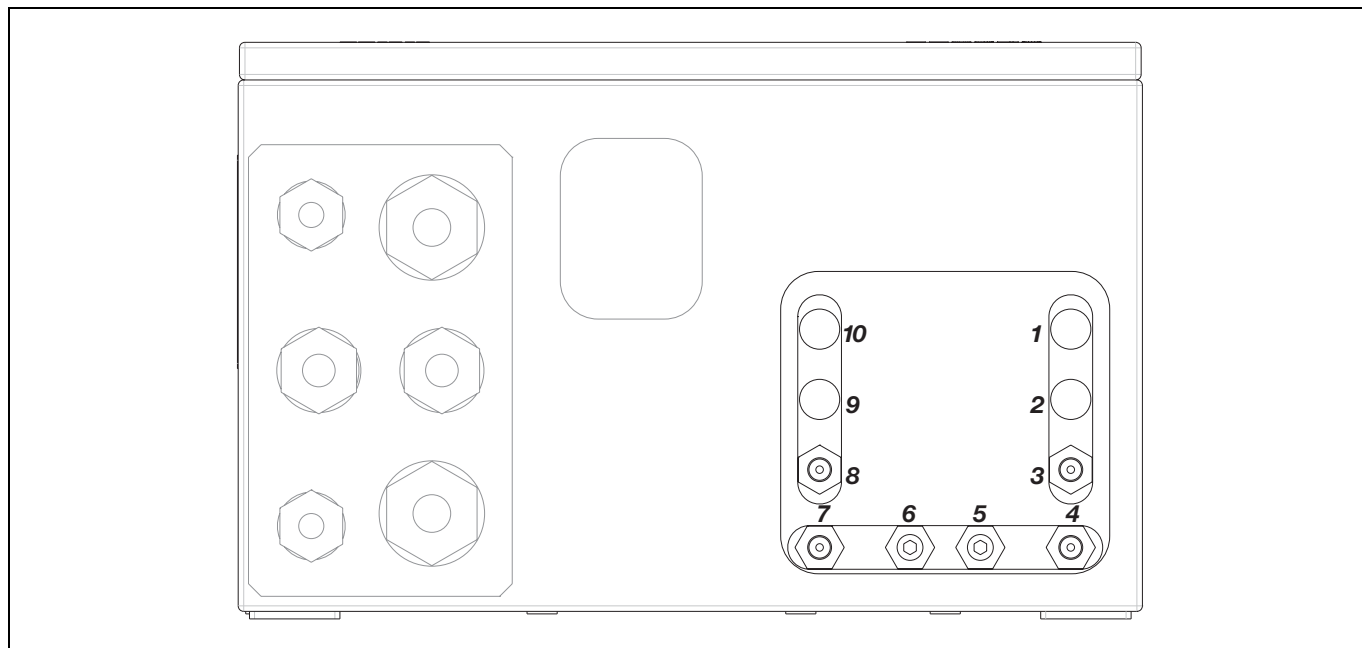

Gas Connections with 1 Gas Path (internal gas paths made up of hoses or stainless steel pipes)

- 1** not used
- 2** not used
- 3** Sample Gas Inlet
- 4** Sample Gas Outlet for one sample cell
- 5** Purge Gas Inlet Housing
- 6** Purge Gas Outlet Housing
- 7** not used
- 8** Sample Gas Outlet for two sample cells in series
- 9** Pressure Sensor (internal gas paths made up of stainless steel pipes)
- 10** not used

Design: 1/8 NPT female thread

Notes: When the internal gas paths are made up of hoses, pressure sensor (standard) and O₂ sensor (option) are connected internally as follows:
downstream the sample cell 1 outlet for one sample cell or for separate gas paths,
downstream the sample cell 2 outlet for two sample cells in series.

When the internal gas paths are made up of stainless steel pipes, O₂ sensor and version with two separate gas paths cannot be provided.

Gas Connections with 2 Separate Gas Paths (internal gas paths made up of hoses)

- 1** not used
- 2** not used
- 3** Sample Gas Inlet Gas Path 1
- 4** Sample Gas Outlet Gas Path 1
- 5** Purge Gas Inlet Housing
- 6** Purge Gas Outlet Housing
- 7** Sample Gas Inlet Gas Path 2
- 8** Sample Gas Outlet Gas Path 2
- 9** not used
- 10** not used

Gas Connections Model EL3040

Analyzer Magnos206

Analyzer Caldos27

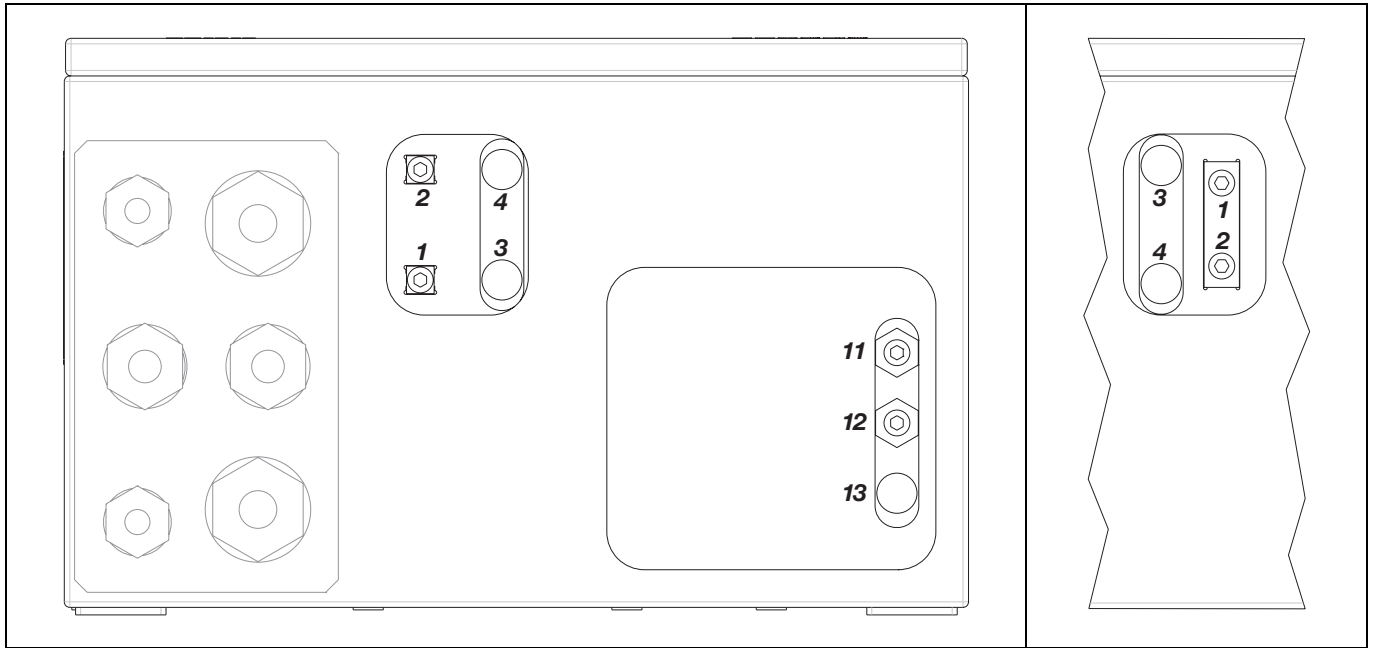

Gas Connections

- 1** Sample Gas Inlet
- 2** Sample Gas Outlet
- 3** not used
- 4** not used
- 11** Purge Gas Inlet Housing
- 12** Purge Gas Outlet Housing
- 13** Pressure Sensor Option for Magnos206, standard for Caldos27

Design: 1/8 NPT female thread

Certifications

CE Declaration of Conformity

The EL3000 Series gas analyzers satisfy the provisions of the following European directives:

73/23/EC (Low Voltage Directive)

89/336/EC (EMC Directive)

94/9/EC (ATEX Directive)

Compliance with the provisions of directive 73/23/EC is evidenced by full compliance with European standard:

EN 61010-1:2001

Compliance with the provisions of directive 89/336/EC is evidenced by full compliance with European standards:

EN 61326: 1997 + A1: 1998 + A2: 2001 + A3: 2003,

EN 61000-3-2: 2000 and EN 61000-3-3: 1995 + A1: 2001

Compliance of the version in Category 3G for measurement of non-flammable gases and vapors with the provisions of directive 94/9/EC is evidenced by full compliance with European standard:

EN 60079-15:2003

Approval for USA and Canada – CSA

The EL3000 Series gas analyzers with housing, integral gas feed and the Uras26, Magnos206 and Caldos27 analyzers are certified for use in general purpose environment, evidenced by full compliance with standard CAN/CSA-C22.2 No. 61010-1-04/UL 61010-1:2004 (2nd Edition).

ABB has Sales & Customer Support expertise
in over 100 countries worldwide.

www.abb.com



ABB Automation GmbH

Analytical
Stierstaedter Strasse 5
60488 Frankfurt am Main
Germany
Phone: +49 69 7930-40
Fax: +49 69 7930-4566
E-Mail: analytical-mkt.deapr@de.abb.com

The Company's policy is one of continuous product
improvement and the right is reserved to modify
the information contained herein without notice.

Printed in the Fed. Rep. of Germany (05.06)

© ABB 2006