

EL6010 Gas Analyzers in Category 2G

EL6010-Uras14 Infrared Analyzer Unit

EL6010-Magnos106 Oxygen Analyzer Unit

EL6010-Caldos17 Thermal Conductivity Analyzer Unit

EL6010-CU Control Unit

- **Product line for gas concentration measurement**
- **Explosion protection category II 2G, i.e. suitability for use in Zone 1 and Zone 2 hazardous areas**
- **Proven measuring technology**
- **Uniform operation and connections**
- **Simplified calibration possible**
- **Output of measurement values, limit and status signals via analog and digital outputs**
- **Extended output and calibration control via RS232/RS485 interface with Modbus protocol**
- **Modbus DDE driver available for data visualization and archiving**
- **Easy menu-driven operation with 4 keys**
- **Modular design for ease of service**



Description

Explosion Protection

The gas analyzers in the EL6010 family are especially designed for use in explosion risk areas. They are certified in accordance with European Directive 94/9/EC ("ATEX Directive").

The housings are pressure-tight capsules and fulfill Explosion Group IIC requirements. For this reason the gas analyzers can even be used in hydrogen or acetylene atmospheres.

The designation is  II 2G EEx de IIC T4.

Device Family Components

The EL6010 family of devices for measuring gas concentrations includes the following analyzers

- EL6010-Uras14 Infrared Analyzer Unit,
 - EL6010-Magnos106 Oxygen Analyzer Unit and
 - EL6010-Caldos17 Thermal Conductivity Analyzer Unit
- as well as the
- EL6010-CU Control Unit.

An EL6010 gas analyzer consists of a control unit and an analyzer unit.

Analyzer Units

The EL6010-Uras14 infrared analyzer unit uses the NDIR (Non-Dispersive Infrared Absorption) technique. It measures concentrations of one or two sample components.

The EL6010-Magnos106 oxygen analyzer unit's measurement principle is based on the specific paramagnetic behavior of oxygen.

The EL6010-Caldos17 thermal conductivity analyzer unit uses the different thermal conductivity of individual gases. It measures the concentration of a sample component in a binary gas mixture.

Each analyzer unit consists of the sensor and its associated electronics.

The analyzer unit is built according to the EN 50018 "Flame-proof Enclosure" protection type. It is contained in a pressure-tight aluminum cylinder.

For corrosion protection purposes the analyzer unit's housing can be purged with air.

The analyzer unit is linked to the control unit by a data transfer cable and a power supply cable.

Control Unit

The EL6010-CU performs the following functions:

- Processing and transmitting measured values provided by the analyzer unit's sensor electronics,
- Correcting sample values, e.g. cross-sensitivity correction,
- Controlling device functions, e.g. calibration,
- Display and control functions,
- Communicating with external systems.

The control unit is also built according to the EN 50018 "Flame-proof Enclosure" protection type. It is installed in a pressure-tight aluminum housing with a viewing glass.

Interfaces

The control unit has

- Two analog outputs for sample values,
- Three digital outputs for status signals and threshold alarm signals and
- A Modbus interface (RS 485 or RS 232) to transfer sample values and status signals to a host system and for controlling calibration.

Operation

Four touch screen fields accessible through the control unit viewing glass allow safe operation of the gas analyzer without opening the housing.

The menu-driven control system is uniform for all three gas analyzers.

Calibration

Essentially the gas analyzer is calibrated manually. External control of calibration is possible via the Modbus interface.

The EL6010-Uras14 infrared analyzer unit can be equipped with optional gas-filled calibration cells that extensively eliminate reliance on test gases.

Because of its very low sensitivity drift, the EL6010-Magnos106 oxygen analyzer unit routinely requires only a zero calibration, if the measurement range is larger than 0–5 Vol.-% O₂. Nitrogen or ambient air are used for this.

Power Supply

The gas analyzer requires a 115 VAC or 230 VAC power supply. The analyzer unit is supplied with 24 VDC by the control unit power supply.

EL6010-Uras14 Infrared Analyzer Unit

Measurement Principle

Non-dispersive infrared absorption in the $\lambda = 2.5\text{--}8\ \mu\text{m}$ wavelength range

Photometer to measure 1 or 2 components with 1 or 2 beam paths

Sample Components and Smallest Measurement Ranges

| Sample Component | Smallest Class 1 Range | Smallest Class 2 Range | Smallest Class 2 Range with Calibration Cell | Gas Group ¹⁾ |
|--------------------------------|------------------------|------------------------|--|-------------------------|
| CO | 0– 100 ppm | 0– 10 ppm | 0– 50 ppm ²⁾ | A |
| CO ₂ | 0– 100 ppm | 0– 5 ppm | 0– 25 ppm ²⁾ | A |
| NO | 0– 200 ppm | 0– 150 ppm | 0– 150 ppm ²⁾ | A |
| SO ₂ | 0– 100 ppm | 0– 25 ppm | 0– 25 ppm ²⁾ | A |
| N ₂ O | 0– 100 ppm | 0– 20 ppm | 0– 50 ppm ²⁾ | A |
| NH ₃ | 0– 500 ppm | 0– 30 ppm | – | B |
| CH ₄ | 0– 100 ppm | 0– 50 ppm | 0– 50 ppm ²⁾ | A |
| C ₂ H ₂ | 0– 200 ppm | 0– 100 ppm | 0– 100 ppm | B |
| C ₂ H ₄ | 0– 500 ppm | 0– 300 ppm | 0– 300 ppm | B |
| C ₂ H ₆ | 0– 100 ppm | 0– 50 ppm | 0– 50 ppm ²⁾ | B |
| C ₃ H ₆ | 0– 250 ppm | 0– 100 ppm | 0– 100 ppm ²⁾ | B |
| C ₃ H ₈ | 0– 100 ppm | 0– 50 ppm | 0– 50 ppm ²⁾ | B |
| C ₄ H ₁₀ | 0– 100 ppm | 0– 50 ppm | 0– 50 ppm ²⁾ | B |
| C ₆ H ₁₄ | 0– 500 ppm | 0– 100 ppm | 0– 100 ppm ²⁾ | B |
| R 134a | 0– 100 ppm | 0– 50 ppm | 0– 50 ppm ²⁾ | B |
| SF ₆ | 0– 2000 ppm | 0– 1900 ppm | 0– 2000 ppm | B |
| H ₂ O | 0– 1000 ppm | 0– 500 ppm | 0– 500 ppm | C |

1) See price information

2) The sample component is calibrated in the factory-set measurement range which can be increased by a factor of 5.

Other sample components on request.

Stability

Linearity Deviation

≤ 1 % of span

Repeatability

≤ 0.5 % of span

Zero Drift

≤ 1 % of span per week.

For ranges smaller than Class 1 to Class 2: ≤ 3 % of span per week

Sensitivity Drift

≤ 1 % of measured value per week

Output Signal Variations (2 σ)

≤ 0.2 % of span at electronic T90 time = 5 sec (Class 1)

Detection Limit (4 σ)

≤ 0.4 % of span at electronic T90 time = 5 sec (Class 1)

Measurement Range Data

Quantity

1 range per sample component.

The measurement range is freely adjustable within a range ratio of ≤ 1:5 relative to the factory-set measurement range.

Largest Measurement Range

0 to 100 Vol.-% or 0 Vol.-% to saturation or 0 Vol.-% to LEL.

Measurement ranges within ignition limits cannot be provided.

Measurement Ranges with Suppressed Zero-Point

Differential measurement with flowing reference gas.

Max. suppression ratio of 1:10 depending on the base level.

Limit Value Monitoring

1 sample component: 2 limit values

2 sample components: 1 limit value per component

Calibration

Zero-Point Calibration

With inert gas, e.g. N₂, or with ambient air that is free of the measurement component

End-Point Calibration

With gas-filled calibration cells (optional) or with test gas mixtures.

Calibration cell set values should be verified periodically

(Recommendation: once a year).

Influence Effects

Flow Effect

Flow rate in the 20–100 l/h range: 0.5 % of span at a flow rate change of ± 10 l/h

Pressure Drop at Flame Barriers

Sample Gas or Reference Gas Inlet: Approx. 40 hPa at a flow rate of 50 l/h. Purge gas inlet: Approx. 20 hPa at a flow rate of 10 l/h

Associated Gas Effect/Cross Sensitivity

Analyzer calibration should be based on an analysis of the sample gas. Selectivity measures to reduce associated gas effect (optional): Incorporation of interference filters, filter vessels or internal electronic cross-sensitivity correction or carrier gas correction for a sample component by other sample components measured with the analyzer unit.

Temperature Effect

- Ambient temperature in permissible range
- At zero-point: ≤ 1 % of span per 10 °C;
for ranges smaller than Class 1 to Class 2:
 ≤ 2 % of span per 10 °C
 - On sensitivity with temperature compensation:
 ≤ 3 % of measured value per 10 °C
 - On sensitivity with thermostat effect at 55 °C (optional):
 ≤ 1 % of measured value per 10 °C

Air Pressure Effect

On sensitivity with pressure correction by means of integral pressure sensor: ≤ 0.2 % of measured value per 1 % barometric pressure change.

The pressure sensor port should not be connected to the sample gas path.

Pressure sensor working range: $p_{\text{abs}} = 600\text{--}1250$ hPa

Dynamic Response

Warm-Up Time

Approx. 30 minutes without thermostat; approx. 2 hours with thermostat.

T₉₀ Time

T₉₀ = 2.5 sec for measurement cell length = 200 mm and sample gas flow = 60 l/h without signal damping (low pass filter).

Materials in Contact with the Sample Medium

Analyzer (Sample Cells)

Tubing: Aluminum or gold-plated aluminum; Window: CaF₂, Option: BaF₂; Connectors: Rust- and acid-resistant steel 1.4571

Gas Lines and Connectors

Rust- and acid-resistant steel 1.4571

EL6010-Magnos106 Oxygen Analyzer Unit

Measurement Principle

Paramagnetic behavior of oxygen

Magnetomechanical oxygen analyzer; short T_{90} time

Sample Component and Smallest Measurement Range

Sample Component

Oxygen (O_2)

Smallest Measurement Range

0 to 1 Vol.-% O_2

Stability

Linearity Deviation

$\leq 0.5\%$ of span

Repeatability

$\leq 0.5\%$ of span (time base for gas exchange ≥ 7 minutes)

Zero Drift

$\leq 3\%$ of span per week. Following prolonged transport and storage time the drift can be higher during the first weeks of operation.

Sensitivity Drift

≤ 0.1 Vol.-% O_2 per week or $\leq 1\%$ of measured value per week (not cumulative), whichever is smaller.

$\leq 0.25\%$ of measured value per year

Output Signal Variations (2σ)

$\leq 0.5\%$ of smallest measurement range span at electronic T90 time
(static/dynamic) = 3/0 sec

Detection Limit (4σ)

$\leq 1\%$ of smallest measurement range span at electronic T90 time
(static/dynamic) = 3/0 sec

Measurement Range Data

Quantity

1 measurement range

The measurement range is freely adjustable; it is factory-set to 0–25 Vol.-% O_2 .

Largest Measurement Range

0–100 Vol.-% O_2

Measurement ranges within ignition limits cannot be provided.

Limit Value Monitoring

2 limit values

Calibration

Zero-Point Calibration

with oxygen-free process gas

End-Point Calibration

with process gas with a known oxygen concentration or with dried air

Single-Point Calibration

For measurement ranges from 0 to 5 Vol.-% O_2 to 0 to 25 Vol.-% O_2
Zero-point calibration with any oxygen concentration, e.g. with nitrogen (N_2) or ambient air, processed through a cooler or H_2O absorber.

Pressure correction by means of pressure sensor is recommended for single-point calibration with air.

Depending on the measurement task involved, the zero- and end-points should be verified periodically (Recommendation: once a year).

Influence Effects

Flow Effect

Sample gas air: 0.1 Vol.-% O₂ at a flow rate change of ±10 l/h;
sample gas N₂: ≤ 0.1 Vol.-% O₂ in permissible range

Pressure Drop at Flame Barriers

Sample Gas Inlet: Approx. 40 hPa at a flow rate of 50 l/h
Purge gas inlet: Approx. 20 hPa at a flow rate of 10 l/h

Associated Gas Effect

The effect of associated gases as a shift of the zero-point ΔZero in Vol.-% O₂ can be estimated using the approximate values in the following table:

| Associated Gas Concentration 100 Vol.-% | | ΔZero in Vol.-% O ₂ |
|---|---------------------------------|--------------------------------|
| Hydrogen | H ₂ | +0.28 |
| Hydrogen Sulfide | H ₂ S | -0.45 |
| Argon | Ar | -0.26 |
| Helium | He | +0.30 |
| Neon | Ne | +0.13 |
| Nitrogen | N ₂ | 0 |
| Nitrogen Oxide | NO | +43 |
| Nitrogen Dioxide | NO ₂ | +28 |
| Nitrous Oxide | N ₂ O | -0.20 |
| Carbon Monoxide | CO | -0.01 |
| Carbon Dioxide | CO ₂ | -0.32 |
| Carbon Oxysulfide | COS | -0.90 |
| Ethane | C ₂ H ₆ | -0.46 |
| Ethene | C ₂ H ₄ | -0.29 |
| Methane | CH ₄ | -0.24 |
| Propane | C ₃ H ₈ | -0.98 |
| Propylene | C ₃ H ₆ | -0.55 |
| Trichloroethane | C ₂ HCl ₃ | -2.17 |
| Vinyl Chloride | CH ₂ CHCl | -0.75 |

Temperature Effect

Ambient temperature in permissible range
– At zero-point: ≤ 0.02 Vol.-% O₂ per 10 °C
– On sensitivity: ≤ 0.1% of measured value per 10 °C
Thermostat temperature = 64 °C

Air Pressure Effect

- On sensitivity with no pressure correction:
≤ 1% of measured value per 1% air pressure change
- On sensitivity with pressure correction using integrated pressure sensor (optional):
≤ 0.01% of measured value per 1% pressure change or
≤ 0.002 Vol.-% O₂ per 1% pressure change, whichever is greater
Pressure sensor working range: p_{abs} = 600–1250 hPa

Position Effect

Zero-point shift ≤ 0.05 Vol.-% O₂ per 1° deviation from horizontal location. Position has no effect on the hard-mounted unit.

Dynamic Response

Warm-Up Time

< 1 hour

T₉₀ Time

T₉₀ ≤ 3.5 at a sample gas flow of 60 l/h and electronic T90 time (static/dynamic) = 3/0 sec, gas change from N₂ to air.

Materials in Contact with the Sample Medium

Analyzer (Sample Chamber)

Rust- and acid-resistant steel 1.4305, glass, platinum, rhodium, epoxy resin. FPM (Viton) seals, optional: FFKM75 (Chemraz™).

Gas Lines and Connectors

Rust- and acid-resistant steel 1.4571.

EL6010-Caldos17 Thermal Conductivity Analyzer Unit

Measurement Principle

Difference in thermal conductivity of various gases

Micromechanical silicon sensor; especially short T_{90} time

Sample Components and Smallest Meas. Ranges

| Sample Component and Associated Gas | Smallest Measurement Range | Smallest Range with Suppressed Zero Point |
|-------------------------------------|----------------------------|---|
| N ₂ in Ar | 0– 6 Vol.-% | 94–100 Vol.-% |
| Ar in N ₂ | 0– 6 Vol.-% | 94–100 Vol.-% |
| Air in CO ₂ | 0– 10 Vol.-% | 90–100 Vol.-% |
| CO ₂ in air | 0– 10 Vol.-% | 90–100 Vol.-% |
| N ₂ in CO ₂ | 0– 10 Vol.-% | 90–100 Vol.-% |
| CO ₂ in N ₂ | 0– 10 Vol.-% | 90–100 Vol.-% |
| N ₂ in CH ₄ | 0– 6 Vol.-% | 94–100 Vol.-% |
| CH ₄ in N ₂ | 0– 6 Vol.-% | 94–100 Vol.-% |
| Air in He | 0– 3 Vol.-% | 99–100 Vol.-% |
| He in air | 0– 1 Vol.-% | 97–100 Vol.-% |
| Ar in He | 0– 3 Vol.-% | 99–100 Vol.-% |
| He in Ar | 0– 1 Vol.-% | 97–100 Vol.-% |
| N ₂ in He | 0– 3 Vol.-% | 99–100 Vol.-% |
| He in N ₂ | 0– 1 Vol.-% | 97–100 Vol.-% |
| Ar in H ₂ | 0– 3 Vol.-% | 99–100 Vol.-% |
| H ₂ in Ar | 0– 1 Vol.-% | 97–100 Vol.-% |
| CO ₂ in H ₂ | 0– 3 Vol.-% | 99–100 Vol.-% |
| H ₂ in CO ₂ | 0– 1 Vol.-% | 97–100 Vol.-% |
| CH ₄ in H ₂ | 0– 3 Vol.-% | 99–100 Vol.-% |
| H ₂ in CH ₄ | 0– 1 Vol.-% | 97–100 Vol.-% |
| N ₂ in H ₂ | 0– 3 Vol.-% | 99–100 Vol.-% |
| H ₂ in N ₂ | 0– 1 Vol.-% | 97–100 Vol.-% |
| O ₂ in Ar | 0– 10 Vol.-% | – |
| H ₂ in air | 0– 1 Vol.-% | – |
| Air in H ₂ | 0– 1 Vol.-% | – |

1) Observe the gas inlet conditions (see page 10)

Stability

The following data apply only if all influence factors (e.g. flow rate, temperature, atmospheric pressure) are constant. They relate to smallest measurement ranges given in the table. The deviations may be larger for smaller measurement ranges.

Linearity Deviation

≤ 2 % of span

Repeatability

≤ 1 % of span

Zero Drift

≤ 2 % of smallest given measurement range per week

Sensitivity Drift

≤ 0.5 % of smallest given measurement range per week

Output Signal Variations (2 σ)

≤ 0.5 % of smallest measurement range span at electronic T90 time
= 0 sec

Detection Limit (4 σ)

≤ 1 % of smallest measurement range span at electronic T90 time =
0 sec

Measurement Range Data

Quantity

1 measurement range

The measurement range is freely adjustable. It is factory-set to relative thermal conductivity (rTC) = 0–60,000.

Largest Measurement Range

0 to 100 Vol.-% or 0 Vol.-% to saturation, depending on measurement task.

Measurement ranges within ignition limits cannot be provided.

Measurement Range with Suppressed Zero Point

See "Sample Components and Smallest Measurement Ranges"

Limit Value Monitoring

2 limit values

Calibration

Zero-Point Calibration

With test gas or with sample component-free process gas

End-Point Calibration

With test gas or with process gas having a known sample component concentration

Measurement Ranges with Suppressed Zero-Point

Zero-point and end-point should only be calibrated with test gases with concentrations in the selected measurement range.

Influence Effects

The following data relate to smallest measurement ranges given in the table. The influence effects may be larger for smaller measurement ranges. The influence effects will be larger at operating altitudes > 2000 meters.

Flow Effect

≤ 0.5 % of span at a flow change of ±10 l/h, within detection limit for equal flow rates of sample and test gas.

Pressure Drop at Flame Barriers

Sample Gas Inlet: Approx. 40 hPa at a flow rate of 50 l/h
Purge gas inlet: Approx. 20 hPa at a flow rate of 10 l/h

Associated Gas Effect

If the sample gas contains components in addition to the sample component (binary gas mixture), this will result in erroneous measurements.

Temperature Effect

Ambient temperature in the range +5 to +50 °C:
At each point in the measurement range: ≤ 0.5 % of span per 10 °C, based on temperature at the time of calibration.
Thermostat temperature = 60 °C

Air Pressure Effect

≤ 0.25 % of span per 10 hPa for the smallest possible ranges given; for larger spans the effect is correspondingly lower.
Pressure sensor working range: $p_{\text{abs}} = 600\text{--}1250$ hPa

Position Effect

< 1% of span up to 30° deviation from horizontal orientation

Dynamic Response

Warm-Up Time

Approx. 30 minutes

T₉₀ Time

$T_{90} \leq 2$ s for sample gas flow of 60 l/h

Materials in Contact with the Sample Medium

Analyzer (Sample Chamber)

Sensor: Gold, silicon oxo-nitride;
Sample chamber: Stainless steel 1.4305
Seal: FFKM75 (Chemraz™)

Gas Lines and Connectors

Rust- and acid-resistant steel 1.4571

Common Technical Data of EL6010-... Analyzer Units

Explosion Protection

Designation

II 2G EEx d IIC T4

EC Type Examination Certificate

DMT 01 ATEX E 037 X + 1st Supplement

Compliance with European Standards

The EL6010-... analyzer units satisfy the following European standards:

| | |
|---------------------------|---------------------------|
| EN 50014 : 1997 + A1 – A2 | General requirements |
| EN 50018 : 2000 | Flame-proof enclosure “d” |

Housing

Design

Pressure-tight aluminum cylinder

Housing Protection Type

IP 54 to IEC 60529 (horizontally mounted with O-ring seals only)

Housing Color

Light gray (RAL 7035)

Dimensions

See dimensional drawing on page 11

Weight

Approx. 26 kg

Housing Purge

Use

To avoid corrosion in corrosive environment or with corrosive sample or associated gases

Types of Operation

To preserve atmospheric conditions in the pressure-tight housing, two types of purge operation are possible:

- Limiting purge gas inlet and outlet pressure to a maximum positive pressure $p_e \leq 100$ hPa ($p_{abs} \leq 1100$ hPa).
- The purge gas is supplied without pressure at the inlet and is extracted from the outlet ($p_e \geq -100$ hPa).

Purge Gas Flow

During operation ≤ 10 l/h

Purge Gas

Clean instrument air from non-explosive areas or an inert gas. The purge gas should not contain any sample gas components.

Gas Connections

Layout and Design

Ports for sample gas, reference gas, purge gas and pressure sensor (optional for EL6010-Magnos106): Internal flame barriers on the bottom of the pressure-tight cylinder with 1/8 NPT internal threads for commercially available adapters, e.g. Swagelok®

Electrical Connections

Data Transmission, Power Supply

Two 3-meter long cables (12 x 0.5 mm² and 3 x 2.5 mm²) securely fastened to the analyzer unit and routed through sealed cable openings, for connection to the EL6010-CU control unit. The cables should not be shortened to a length of ≤ 1 meter.

Gas Inlet Conditions

The EL6010-... analyzer units are capable of measuring flammable and non-flammable gases under atmospheric conditions which occasionally can be explosive.

Flammable and Non-flammable Gases under Atmospheric Conditions

- The maximum oxygen content of the sample gas mixture should be 21 Vol.-%, corresponding to atmospheric conditions.
- If the sample gas consists only of oxygen as well as flammable gases and vapors, it must not be explosive under any conditions. As a rule this can be achieved by limiting oxygen content to a maximum of 2 Vol.-%.
- Flammable gases that are explosive under the conditions encountered in analysis even when oxygen is excluded should be present in the mixture only in concentrations that are not critical to safety.

Corrosive Gases

The EL6010-... analyzer units must not be used for the measurement of corrosive gases. Gases like chlorine (Cl₂) and hydrogen chloride (e.g. wet HCl) as well as gases or aerosols containing chlorine must be cooled or undergo prior absorption.

Temperature

| | |
|------------------|--------------|
| EL6010-Uras14 | +5 to +45 °C |
| EL6010-Magnos106 | +5 to +50 °C |
| EL6010-Caldos17 | +5 to +50 °C |

The sample gas dew point should be at least 5 °C below the lowest ambient temperature throughout the sample gas path. Otherwise a sample gas cooler or condensate trap is required. Water vapor content variations cause volume errors.

Inlet Pressure

Atmospheric conditions $p_e \leq 100$ hPa/ $p_{abs} \leq 1100$ hPa

Outlet Pressure

Atmospheric pressure

Flow Rate

| | |
|------------------|-----------------------------------|
| EL6010-Uras14 | 20–100 l/h |
| EL6010-Magnos106 | 20–60 l/h |
| EL6010-Caldos17 | normally 10–90 l/h, minimum 1 l/h |

Installation Site Requirements

The EL6010-... analyzer units must not be installed outdoor.

Vibration

| | |
|------------------|--|
| EL6010-Uras14 | max. ±0.04 mm at 5–55 Hz, 0.5 g at 55–150 Hz, slight transient effect on sample value in the region of the beam modulation frequency |
| EL6010-Magnos106 | max. ±0.04 mm at 5–20 Hz |
| EL6010-Caldos17 | max. ±0.04 mm at 5–55 Hz, 0.5 g at 55–150 Hz |

Ambient Temperature

Operation, compliance with measurement-related data:

| | |
|------------------|--------------|
| EL6010-Uras14 | +5 to +45 °C |
| EL6010-Magnos106 | +5 to +50 °C |
| EL6010-Caldos17 | +5 to +50 °C |

Operation, no impairment of explosion protection:

| | |
|------------------|---------------|
| EL6010-Uras14 | -20 to +45 °C |
| EL6010-Magnos106 | -20 to +50 °C |
| EL6010-Caldos17 | -20 to +50 °C |

Storage and transport: -25 to +65 °C

Note

Measurement data of the EL6010-... analyzer units are based on N₂ as the associated gas. Compliance with these data when measuring other gas mixtures can only be assured if their composition is known.

Dimensional and Connection Drawing of the EL6010-... Analyzer Units (dimensions in mm)

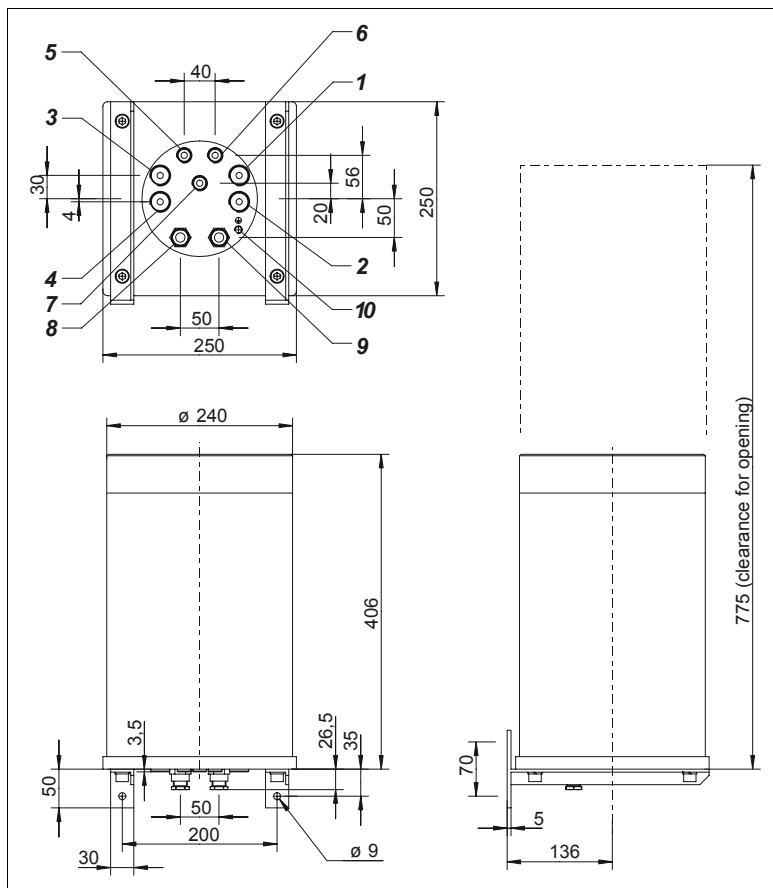

EL6010-Uras14

Gas Connections:

- 1) The actual sample gas inlet and outlet configuration
- 2) is documented in the "Analyzer Data Sheet" supplied
- 3) with the instrument.
- 4)
- 5 Purge Gas Inlet²⁾
- 6 Purge Gas Outlet²⁾
- 7 Pressure Sensor³⁾

Electrical Connections:

- 8 Data Transmission Cable Feed-through
- 9 24 VDC Power Supply Cable Feed-through
- 10 Potential Compensation Connector

EL6010-Magnos106, EL6010-Caldos17

Gas Connections:

- 1 Sample Gas Inlet
- 2 Sample Gas Outlet
- 3 not used
- 4 not used
- 5 Purge Gas Inlet¹⁾
- 6 Purge Gas Outlet¹⁾
- 7 Pressure Sensor²⁾ (EL6010-Magnos106: optional)

Electrical Connections:

- 8 24 VDC Power Supply Cable Feed-through
- 9 Data Transmission Cable Feed-through
- 10 Potential Compensation Connector

1) Option
 2) The pressure sensor port should not be connected to the sample gas path when measuring flammable and corrosive gases.

EL6010-CU Control Unit

Explosion Protection

Designation

 II 2G EEx de IIC T4

EC Type Examination Certificates

CESI 01 ATEX 036

PTB 01 ATEX 1118

Compliance with European Standards

The EL6010-CU control unit satisfies the following European standards:

EN 50014 General requirements
 EN 50018 Flame-proof enclosure "d"
 EN 50019 Increased safety "e"

Housing

Design

Pressure-tight aluminum housing with viewing glass and EEx-e connection box

Housing Protection Type

IP 65 to IEC 60529

Housing Color

Light gray (RAL 7035)

Dimensions

See dimensional drawing on page 13

Weight

Approx. 19 kg

Electrical Connections

see page 13

Display and Operation

Display

Illuminated LC Display with 2 x 20 characters

Readout Resolution

Better than 0.2 % of measurement span

Operation

Four keys: Up, Down, Enter, Back.

Capacitive keys for operation through the viewing glass.

Electrical Safety

Tested per EN 61010-1

Protection Class

I

Overload Category

Power supply: II
 Signal inputs and outputs: II

Pollution Level

2

Safe Isolation

The power supply is galvanically isolated from other circuits by means of reinforced or double insulation.

Electromagnetic Compatibility

Noise Immunity

Tested per EN 61326-1:1997 and EN 61326/A1:1998
 Severity: Industrial area, fulfills at least the requirements of the "continuously monitored operation" rating per EN 61326-1 Table 2.

RF Suppression

Tested per EN 61326-1:1997, EN 61326/A1:1998,
 EN 61000-3-2:1998 + A14/00 and EN 61000-3-3:1995
 Threshold Class B for interference field strength and interference voltages is maintained.

Power Supply

Input Voltage

85–250 VAC, 48–63 Hz

The power supply must be fused on site with 6 A.

Power Consumption

| | |
|------------------------------|----------------|
| EL6010-CU + EL6010-Uras14 | approx. 100 VA |
| EL6010-CU + EL6010-Magnos106 | approx. 90 VA |
| EL6010-CU + EL6010-Caldos17 | approx. 40 VA |

Installation Site Requirements

The EL6010-CU control unit must not be installed outdoor.

Ambient Temperature

as for EL6010-... analyzer units (see page 11)

Relative Humidity

< 75 %

Dimensional Drawing of the EL6010-CU Control Unit (dimensions in mm)

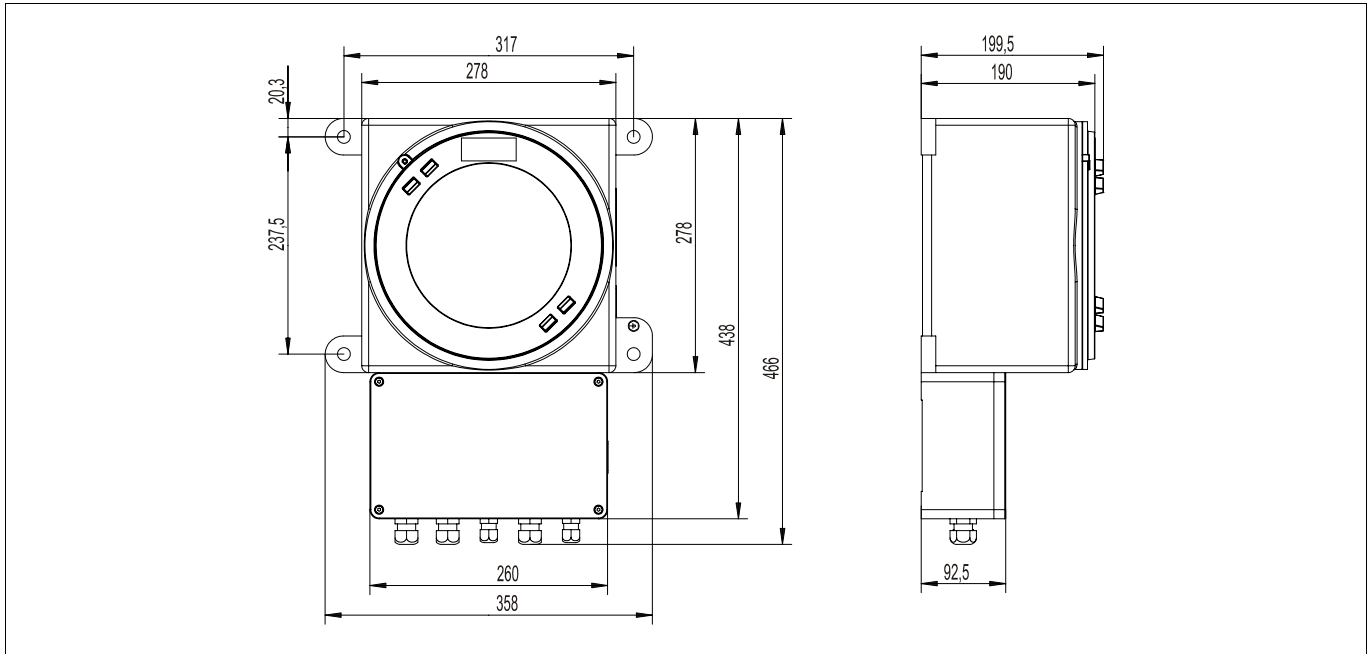

Electrical Connections of the EL6010-CU Control Unit (conductor cross-section $\leq 2.5 \text{ mm}^2$)

| | | | | |
|----|-------|--------------------|--|---|
| 1 | 1 | LDA | | Data Transmission to/from Analyzer Unit |
| 2 | 2 | LCL | | |
| 3 | 3 | TINT | | |
| 4 | 4 | RX_B | | |
| 5 | 5 | RX_A | | |
| 6 | 6 | TX_B | | |
| 7 | 7 | TX_A | | |
| 8 | 8 | 485EN_B | | |
| 9 | 9 | 485EN_A | | |
| 10 | 10 | RESET | | |
| 11 | 11 | S_DOWN | | |
| 12 | 12 | GND | | |
| 13 | | PE | | Analyzer Unit Power Supply |
| 14 | | 24 VDC + | | |
| 15 | | GND | | |
| 16 | RxD | RS232 | | Serial Interfaces Transfers sample values and status signals to host systems, e.g. to standard Windows applications via Modbus DDE-Server. Modbus slave protocol in RTU (remote terminal unit) mode. Either the RS232 or the RS485 interface can be used (configurable). Interface galvanically isolated from ground. |
| 17 | TxD | | | |
| 18 | GND | | | |
| 19 | RTxD- | RS485 | | |
| 20 | RTxD+ | | | |
| 21 | GND | | | |
| 22 | | Collective Status | | Digital Outputs Floating double-throw contacts, max. contact load rating 30 VDC / 1 A. Relays are shown in the unpowered state. The unpowered state is the failure mode ("fail safe"). |
| 23 | | | | |
| 24 | | | | |
| 25 | | Limit Value 1 | | |
| 26 | | | | |
| 27 | | | | |
| 28 | | Limit Value 2 | | |
| 29 | | | | |
| 30 | | | | |
| 31 | + | Sample component 1 | | Analog Outputs 4-20 mA, common negative pole, galvanically isolated from ground, freely connectable to ground, max. gain relative to protective ground potential 50 V, max. working resistance 750 Ω . The output signal cannot be lower than 0 mA. |
| 32 | - | | | |
| 33 | + | Sample component 2 | | |
| 34 | - | | | |
| N | | | | Power Supply 85-250 VAC, 48-63 Hz |
| L | | | | |
| PE | | | | |

CE Compliance Statement

The EL6010 gas analyzers satisfy the provisions of the following European directives:

73/23/EC

Electrical Equipment Designed for Use within Certain Voltage Limits

Compliance with the provisions of the directive is evidenced by full compliance with European standard EN 61010-1:2001.

89/336/EC

Electromagnetic Compatibility

Compliance with the provisions of the directive is evidenced by full compliance with European standards EN 61326-1: 1997, EN 61326/A1: 1998, EN 61000-3-2: 1998 + A14/00 and EN 61000-3-3: 1995.

94/9/EC

Equipment and Protective Systems Intended for Use in Potentially Explosive Atmospheres

Compliance with the provisions of the directive is evidenced by full compliance with European standards EN 50014, EN 50018 and EN 50019.

ABB has Sales & Customer Support expertise
in over 100 countries worldwide.

www.abb.com



ABB Automation GmbH

Analytical
Stierstaedter Strasse 5
60488 Frankfurt am Main
Germany
Phone: +49 69 7930-40
Fax: +49 69 7930-4566
E-Mail: analytical-mkt.deapr@de.abb.com

The Company's policy is one of continuous product
improvement and the right is reserved to modify
the information contained herein without notice.

Printed in the Fed. Rep. of Germany (06.07)

© ABB 2007