



PSS-10/1

Portable Gas Conditioning Unit Series PSS[®]

Version

PSS-10/1 for 480 NI/hr gas flow rate

- **Low maintenance and self-monitoring**
- **Dew point +5 °C ±0,1 °C**
- **Operational in 20 minutes**
- **Compact construction**
- **Light weight**
- **Optimum reliability**
- **Patented Jet-Stream heat exchanger**
- **Universal equipment possible**

Application

The portable gas conditioning unit **PSS-10/1** is designed to carry out precise gas analyses at different locations. The entire gas conditioning unit is housed in a robust aluminium-frame case to enable you to carry out your gas analysis rapidly, safely and with little maintenance work. The **PSS-10/1** gas conditioning unit is suitable for variable, discontinuous use as for continuous operation. The components built into the **PSS-10/1** gas conditioning unit are envisaged for "standard use". Obviously our extensive Product Range provides additional components.

Description

The **M&C PSS-10/1** gas conditioning unit is fitted with an two stage **ECP20-2** gas cooler which cools the sample gas to a constant + 5 °C irrespective of the ambient temperature. As soon as the operating temperature of < +8 °C is reached after start up, the gas pump **N9 KPE** is switched on automatically by the gas cooler status contact. The **SR 25.1** peristaltic pumps ensures a constant condensate drain, making long-term measurement possible without problems. The corresponding particle filtration is carried out by the **FP-2T** micron filter. This all makes the portable gas conditioning unit a complete gas conditioning system for most gas-analysis devices.

Flow scheme PSS-10/1

- 1 Gas sample probe
- 2 Sample line, 3 m Viton hose
- 3 Gas cooler ECP 20-2
- 4 Fine filter FP-2T, filter porosity 2 µm
- 5 Gas diaphragm pump N9KPE
- 6 optional flowmeter FM 40
- 7 Pre-filter PF2
- 8 Peristaltic pump SR25.1

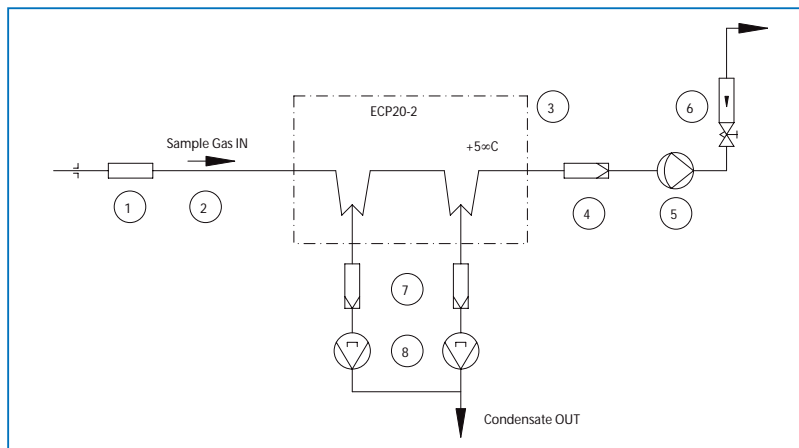

Dimensions

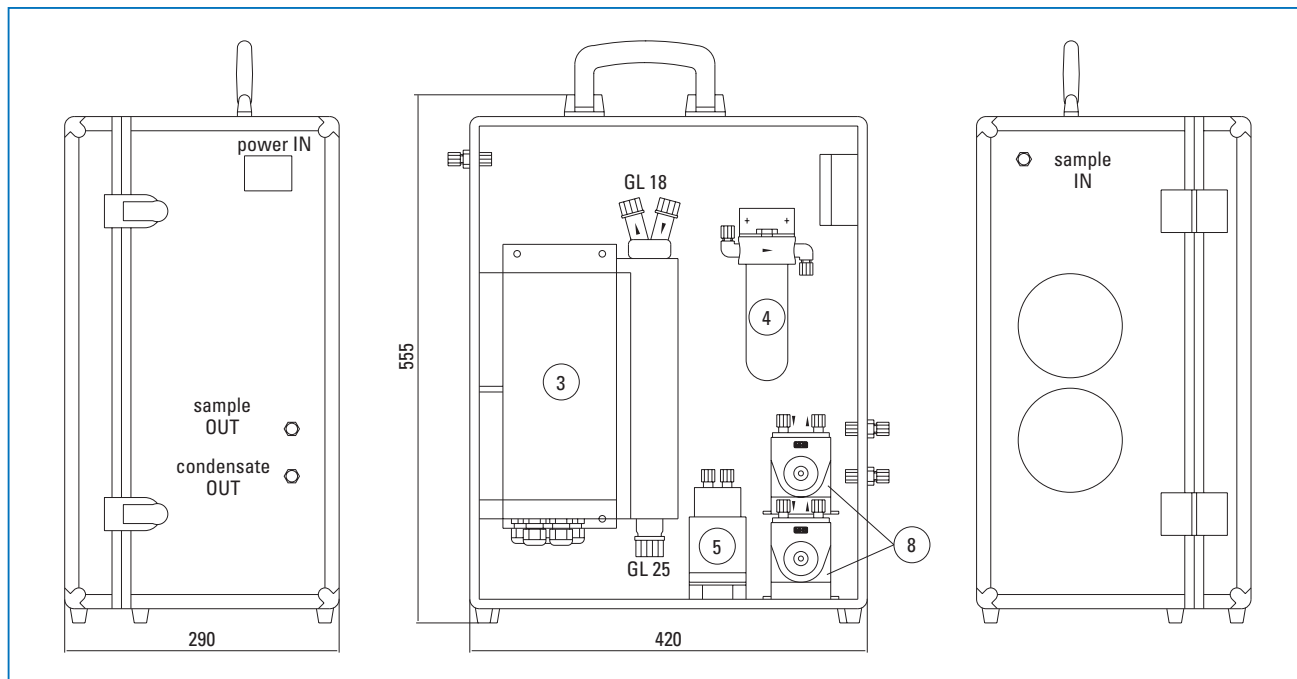

Dimensions in mm

Technical Data

Gas Conditioning Unit series PSS®		version PSS-10/1
Part No. for 230V 50Hz version	01G5000	
Part No. for 115V 60Hz version	01G5000a	
Sample outlet dew point	+5 °C	
Sample inlet temperature	**max. 80 °C optional: **max.180 °C with stainless steel bulkhead union	
Sample inlet dew point	**max.+80 °C	
Gas flow rate	**max. 480 NI/hr	
Ambient temperature	**+5 °C up to +40 °C	
Storage temperature	-25 °C up to +65 °C	
Pressure	0,7 bar up to 1,4 bar abs.	
Total cooling capacity	**max. 80 kJ/hr	
Number of gas inlets	1	
Number of gas outlets	1 optional: max. 4	
Medium connections	tube connection 4/6 mm	
Material of sample contacting parts	stainless steel, glass, PVDF, Viton®, Novoprene®	
Ready for operation	approx. 10 min.	
Power supply	230V 50Hz or 115V 60Hz	
Power consumption	max. 350VA; with option temperature controller and heated sample line 230V: max.1730VA 115V:max. 1040VA	
Fuse protection	4A t, 5x 20 mm, with option temperature controller: 6,3A t	
Electrical connection	Cold appliance plug with 2 m of cable	
Case protection	IP20 (DIN 40050. IEC 529)	
Housing	portable aluminium-frame case	
Housing dimensions	555 mm x 460 mm x 290 mm (H x W x D)	
Electrical equipment standard	EN61010	
Weight	approx. 24 kg	
Options	Type	Part No.
Further sample gas outlet	Parallel sample gas outlet, tubing via T-piece on lateral PVDF bulkhead fitting, DN4/6, max. 4 pieces	01G9065
Flowmeter, max. 4 pieces	FM40 7-70 l/hr air, mounted in sample gas outlet	01G9070
	FM40 15-150 l/hr air, mounted in sample gas outlet	01G9075
	FM40 25-250 l/hr air, mounted in sample gas outlet	01G9080
	FM40 50-500 l/hr air, mounted in sample gas outlet	01G9085
Fittings out of PVDF	Fittings out of PVDF instead of PP and 3m FPM sample tube DN4/6	01G9025
Sample tube	Sample tube out of Kanthal® ø 6 mm, length 1 m, sampling temperature max. 1300 °C	01G9030
Liquid alarm	Liquid alarm LA 1/1.2, consisting of: liquid alarm sensor LA1, controller LA1.2, filter glass F120G-D with GL connection incl. moutange/wiring. In case of condensate inrush, the sample gas pump is automatically switched of.	01G9035
3-way ball valve	3L/PV-1 for switching over from test gas to sample gas, in the inlet of the sample gas conditioning unit, mounted with mounting brackets, fitting PVDF	01G9046
5-way ball valve	5L/PV-1 for switching over from test gas to sample gas, in the inlet of the sample gas conditioning unit, mounted with mounting brackets, fitting PVDF	01G9045
Electronic temperature controller for max. 12 m heated sample line 100W/m	TRM 1.2 control range 0-200 °C, inlet PT100, power 230V 50Hz, Contact capacity 250V AC max. 4A, completely mounted incl. 7-pin plug 10A	01G9055
Electronic temperature controller for max. 12 m heated sample line 100W/m	TRM 1.2 control range 0-200 °C, inlet PT100, power 115V 60Hz, Contact capacity 250V AC max. 4A, completely mounted incl. 7-pin plug 10A	01G9055a
Connecting adapter DN4/6 for heated sample line	PSS-10 connecting adapter with bending protection for rigid moutange of heated sample line with interchangeable PTFE tube DN4/6, consisting of stiffening plate, Swagelok fitting with 4mm cartridge, material: SS316Ti.	01G9062
Connecting adapter DN6/8 for heated sample line	PSS-10 connecting adapter with bending protection for rigid moutange of heated sample line with interchangeable PTFE tube DN6/8, consisting of stiffening Swagelok fitting with 4mm cartridge, material: SS316Ti.	01G9063

PP = Polypropylene

PTFE = Polytetrafluoroethylene (Teflon®)

PVDF = Polyvinylidenfluoride

** Maximum values in technical data must be rated in consideration of total cooling power at 25 °C.

Other versions on request.