

# UNITHERM™ 2256/2266 Parallel Circuit Self-Regulating

## Principal of Operation

Unitherm 2256/2266 self-regulating electric trace tubing is comprised of a self-regulating heating element laid parallel to the process tubes, a heat reflection foil wrap, moisture resistant, non-wicking, inorganic fibrous glass thermal insulation, and a 105°C black PVC jacket. The highly efficient **LTM** design will provide freeze protection (40°F, 4.4°C) at ambient temperatures down to -40°F (-40°C). The **HTM** design will provide a minimum process tube temperature of 100°F (38°C) at -40°F (-40°C) ambient. Designs are approved for Class I, Division 2, Groups B, C & D; Class II, Division 2, Groups F & G; Class III, Division 2 areas.

## Features

- Self-regulating heating element
- Pre-insulated and prefabricated for fast, easy installation.
- Consistent and predictable thermal characteristics.

## Applications

- Analyzer and instrument lines
- Small diameter process lines
- Impulse lines

## How to Specify

### Example:

### 2266-20A30

Unitherm self-regulating LTM electric trace tubing (2) 1/4" O.D. x .035" wall 316-Welded S/S tube; (1) 5 watts/ft @ 120 VAC self-regulating heating element; moisture resistant, non-wicking, inorganic fibrous glass thermal insulation; 105°C black PVC jacket; MTR\*\*= 185°F

\*\*Maximum Temperature Rating is the design condition for which this product is manufactured. Temperatures in excess of this rating may result in deterioration of the components or changes in the operational characteristics.

2256  
Single Tube

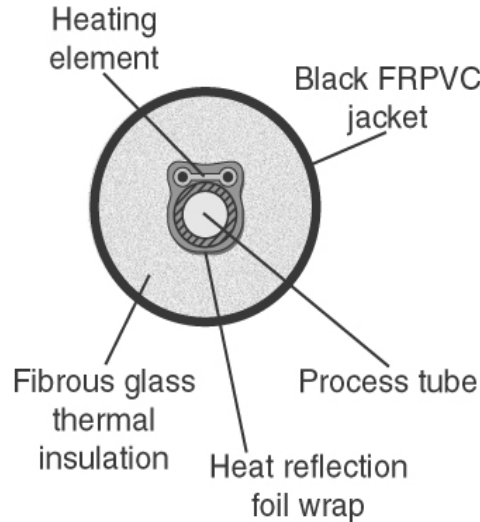

2266  
Dual Tube

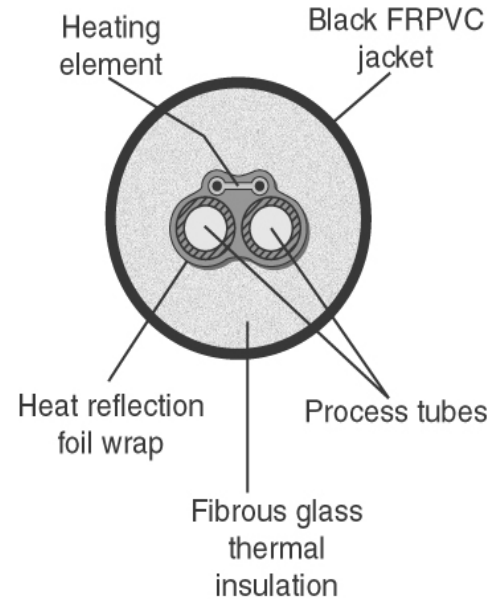

## Electrical Specifications

The heating element is composed of two parallel stranded nickel-plated copper bus wires uniformly connected with an extruded semi-conductive web, having a positive temperature resistance coefficient. The element is covered with a protective plastic jacket to provide electrical protection and an outer metallic braid is added to provide a fault current path to ground.

- Bus Wires.....16 AWG stranded nickel-plated copper
- Jacket.....18 mill minimum thickness plastic composite or Fluoropolymer
- Metallic Braid.....34 AWG tinned copper
- Operating Voltage.....120 or 240 volts depending upon heater rating

Rating	Maximum Circuit Length (Ft.) 120V / 240V	Maximum Temperature Rating
5 watts/ft. Low Temp	270/540	185°F / 85°C
10 watts/ft. High Temp	180/280	366°F / 185°C

The 2256 and 2266 products are approved by Factory Mutual for use in the following hazardous locations:

- (1) Class I, Division 2, Groups B, C, and D
- (2) Class II, Division 2, Groups F & G
- (3) Class III, Division 2

These locations are as defined by the National Electrical Code – National Fire Protection Association No. 70, articles 500 through 503.

## Performance Curves 2256/2266

### How to use Graphs

The graphs plot the expected process tube temperature vs. ambient for the size and the three standard bundle tube sizes and the two standard heaters.

To determine the process tube temperature, draw a line vertically upward from the ambient temperature until it intersects the tube size line for the given bundle.

Then, draw a line horizontally to the left until it intersects the process tube temperature axis and read the temperature.

Circuit breaker sizing should be based upon the circuit breaker selection chart for the lowest temperature condition at which the system may be energized. The 2256/2266 products, using the SR heater should be controlled with an ambient sensing thermostat. The thermostat should be set to close approximately 5°F higher than the lowest allowable process tube temperature. Load requirements of the thermostat should be based upon the circuit breaker selection.

### 2256/66 Low Temp

Breaker Sizing vs Max Circuit Length (feet)					
if	15A	20A	30A	40A	
started	120V 240V	120V 240V	120V 240V	120V 240V	
@50°F	230 460	270 540	-- --	-- --	
@0°F	150 300	200 400	270 540	-- --	
@-20°F	130 260	175 345	260 520	270 540	

### 2256/66 High Temp

Breaker Sizing vs Max Circuit Length (feet)					
if	15A	20A	30A		
started	120V 240V	120V 240V	120V 240V		
@50°F	90 140	120 190	180 280		
@0°F	85 130	110 175	165 260		
@-40°F	80 125	105 170	160 250		

Due to imaging and distortion chart points can only be used for approximations.

### Process Tube Temperature Vs. Ambient Temperature for:

#### 2256 Self-Regulating Tubing - LT Low Temperature Maintenance

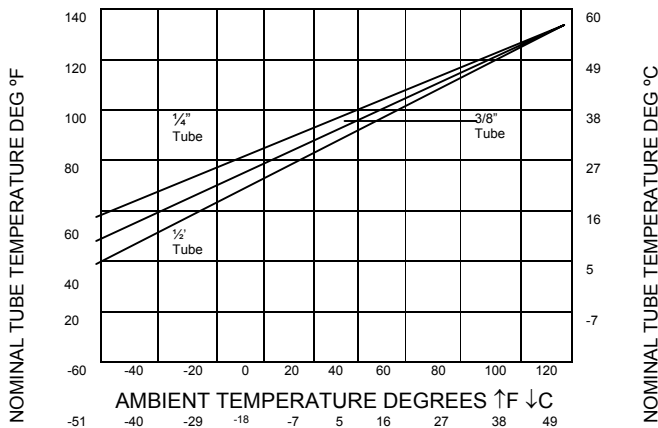

#### 2266 Self-Regulating Tubing - LT Low Temperature Maintenance

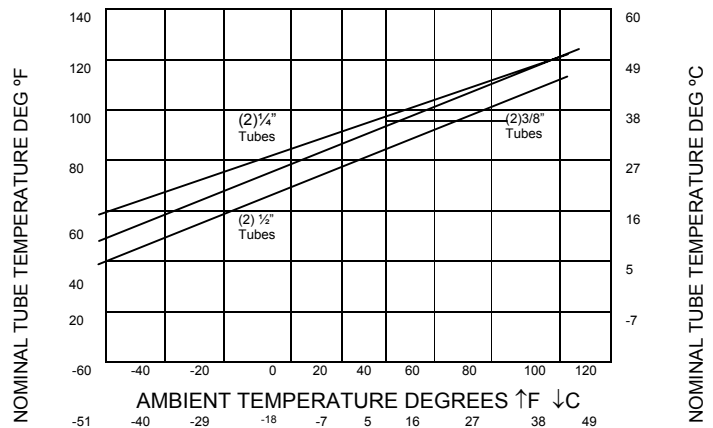

#### 2256 Self-Regulating Tubing - HT High Temperature Maintenance

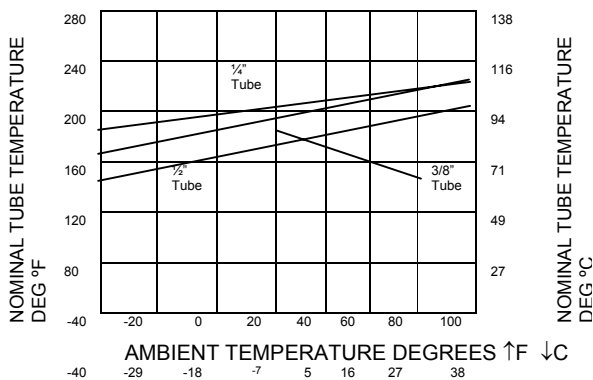

#### 2266 Self-Regulating Tubing - HT High Temperature Maintenance

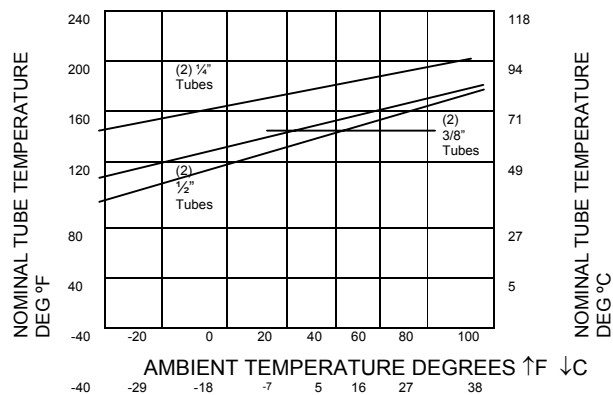

Due to imaging and distortion chart points can only be used for approximations.

**Bundle Wired  
Directly to Thermostat**

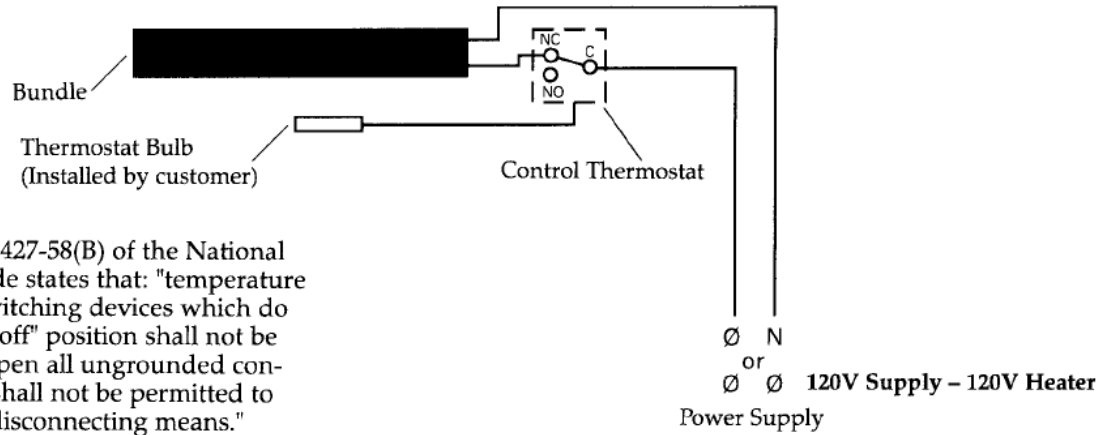

**Bundle Wired  
With Two Pole Contactor**

